

# DELTA-PRISMA 4WD

## Bodywork



**Service  
Manual**

DIAGRAM FOR CHECKING UNDERBODY

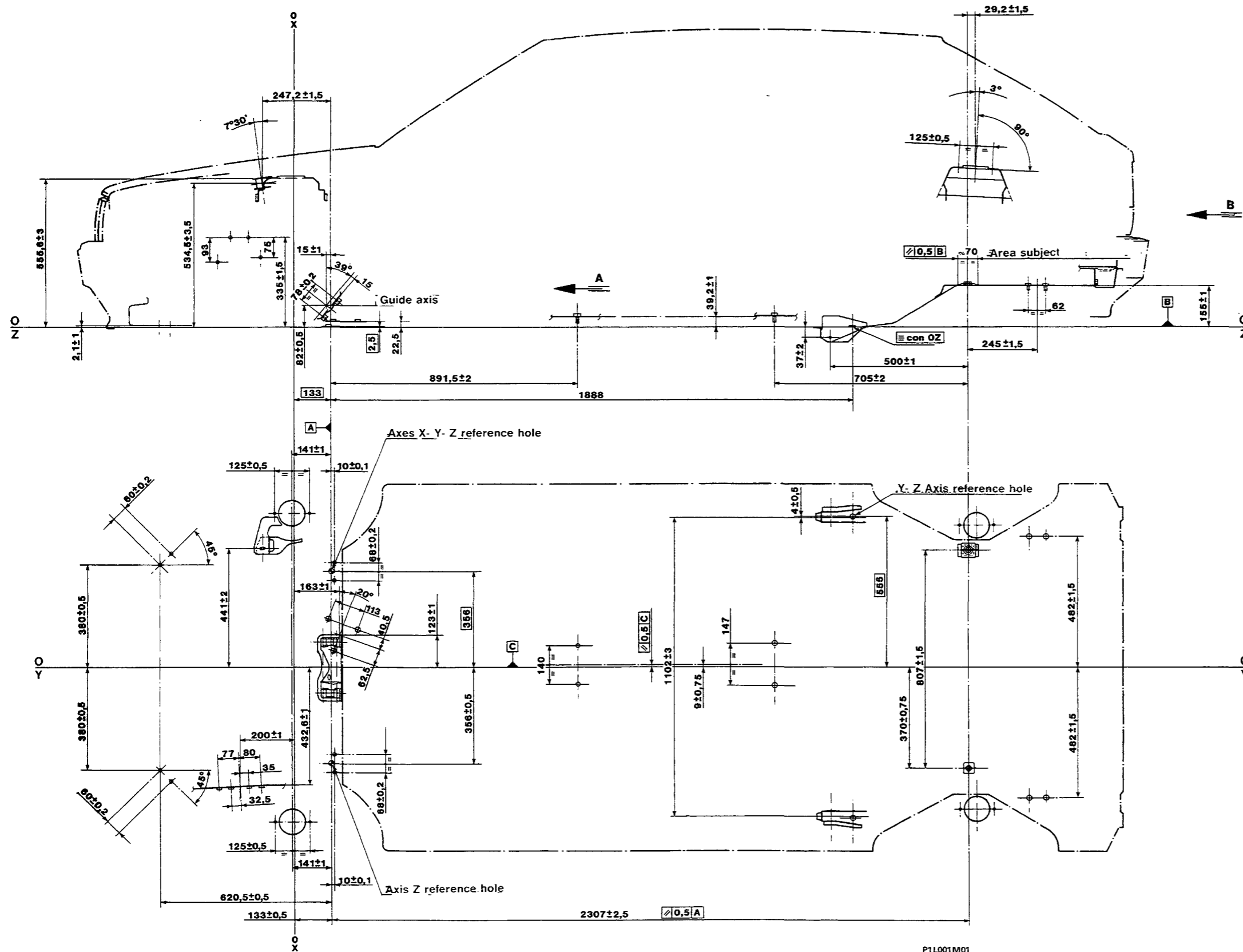

P1L001M01

70.

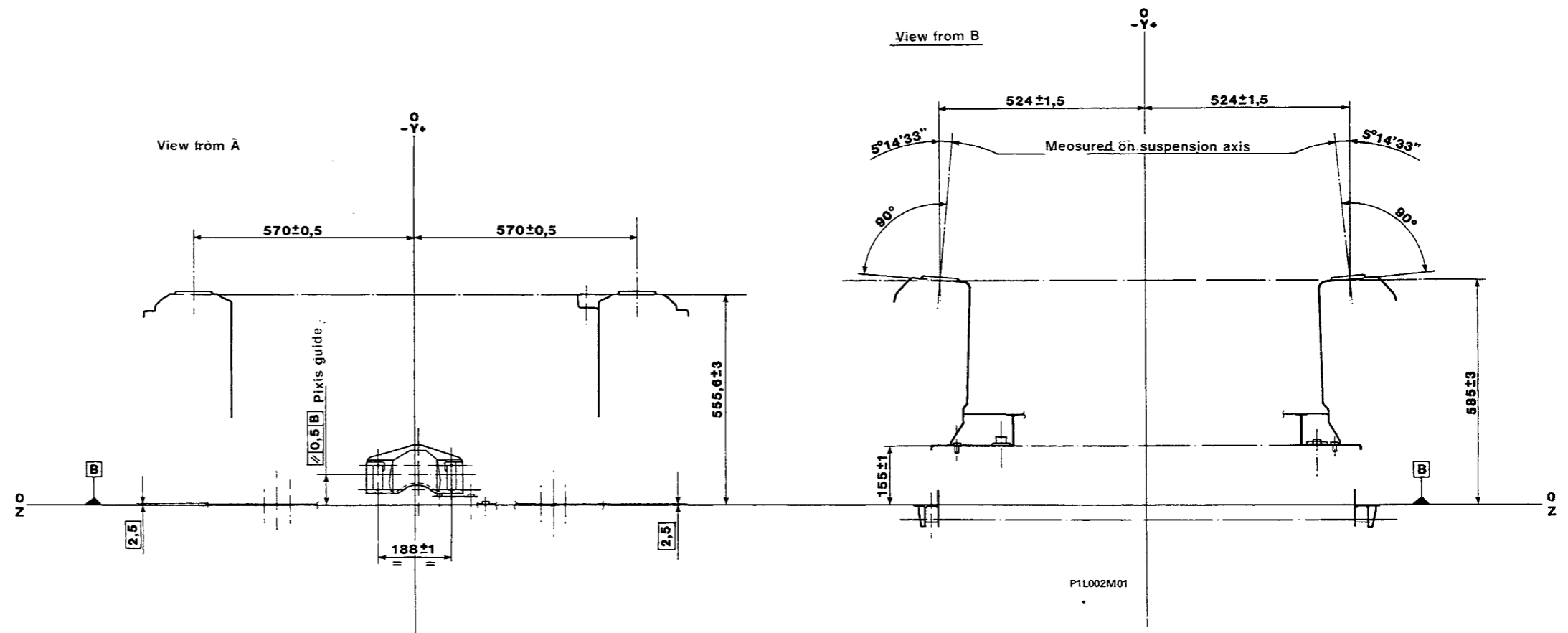

## BONNET LID

## Vertical adjustment

The arrows show the direction in which the bonnet lid can be adjusted by means of the slots on the hinges.

**NOTE** *It is necessary to remove the radiator trim in order to be able to get at the bolts for making vertical adjustment to the bonnet lid.*

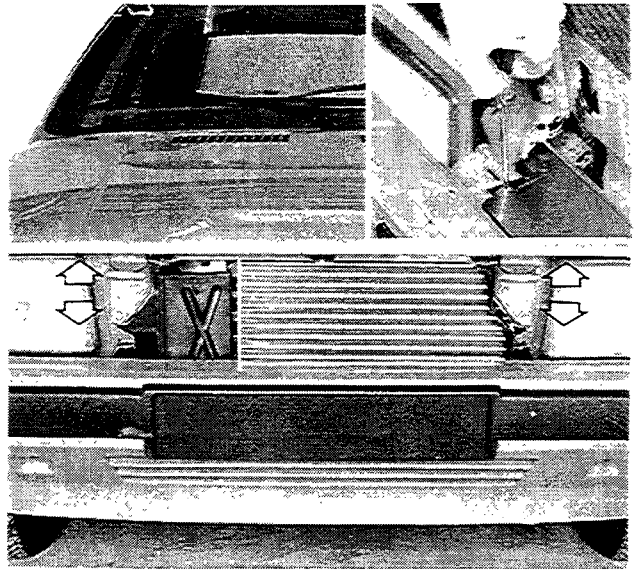

## Adjusting transverse position

The arrows show the direction in which the bonnet lid can be adjusted by means of the slots on the hinges.

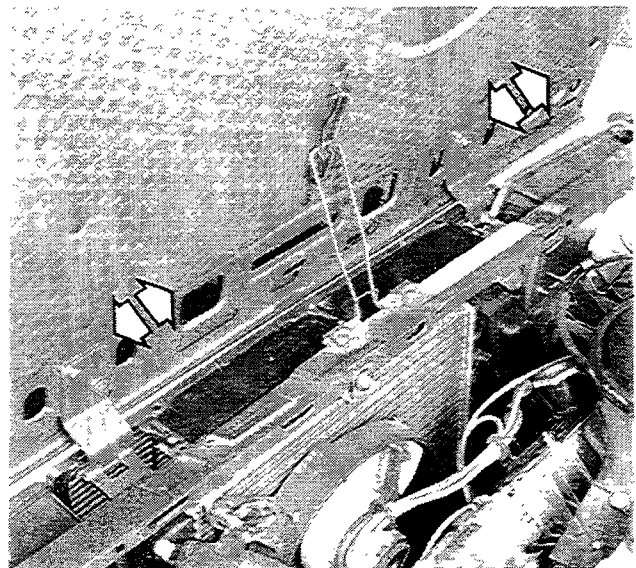

## Adjusting the device for locking the bonnet lid

Getting the bonnet lid to lock properly is done by adjusting not only the bolts securing the 2 locking devices, but also the rubber blocks at the ends of both the engine compartment and the bonnet lid.

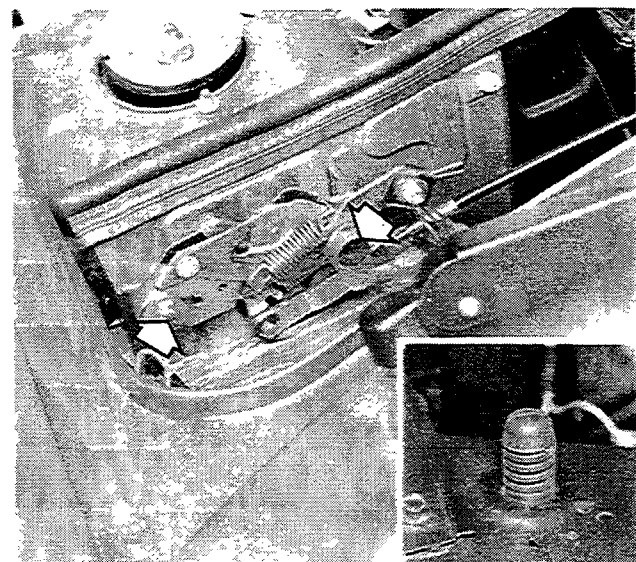



**70.**

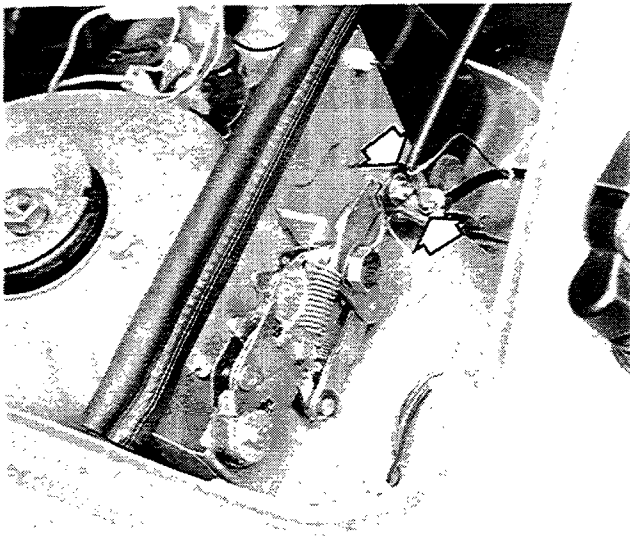

Removing — refitting bonnet release rods from lock.

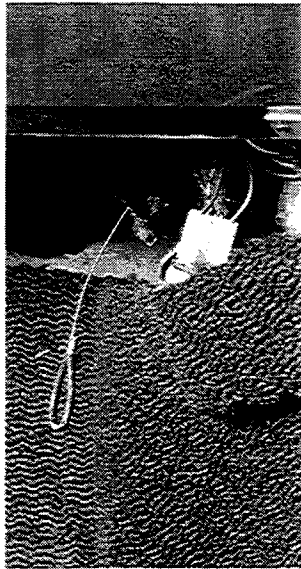
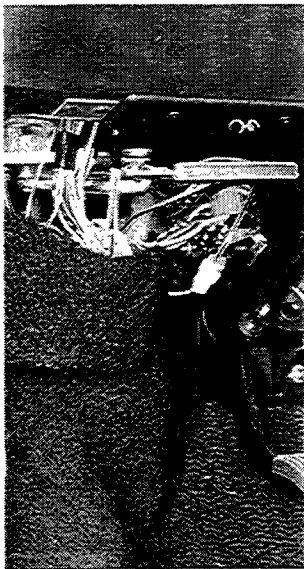

Removing — refitting body release rod from operating lever and replacing rod for emergency opening.

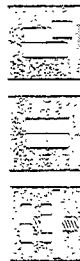
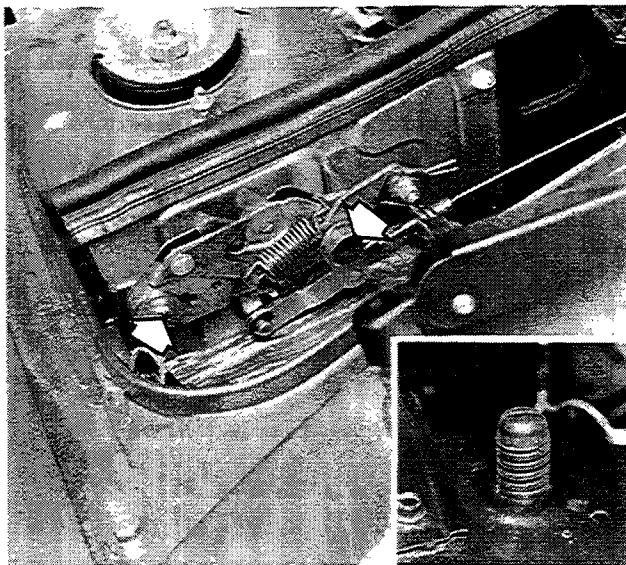

Removing — refitting and adjusting device for locking bonnet lid.

When refitting, check that the bonnet lid is correctly lined up and that it closes properly. If necessary, loosen the screws and move the lock sideways.

**NOTE** *If the bonnet lid locks properly but is either too high or too low with respect to other parts with which it should line up, adjust the rubber blocks accordingly.*

DOORS

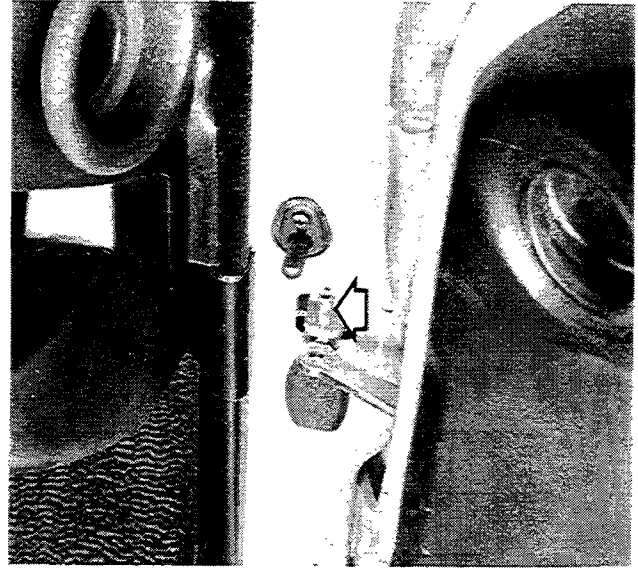

Removing — refitting device for limiting door openings.

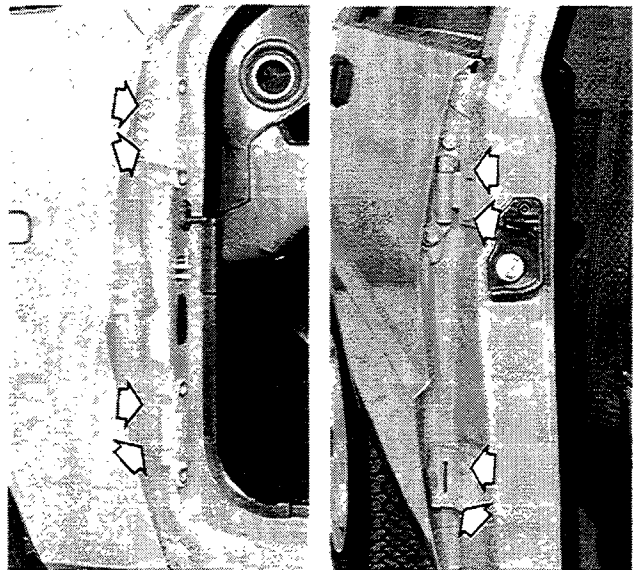

Removing — refitting and adjusting front and rear doors.

**NOTE** After having refitted the door check on its position. If it is too far in or too far out with respect to the rest of the bodywork, either add or remove shims between the hinge and the pillar. If, on the other hand, the clearance between the door and the wheel arch or the ribs does not coincide with what it ought to be, loosen the bolts shown by the arrows and move the door accordingly.

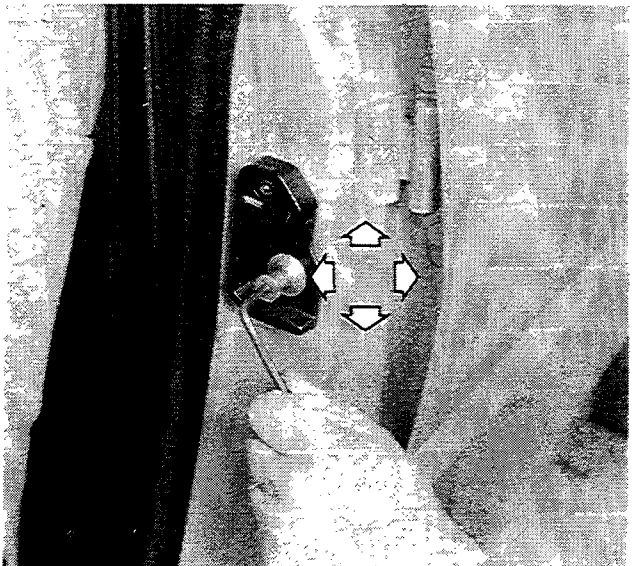

Adjusting lock striker

The arrows show the ways in which the striker can move to adjust the door locks.

**70.**

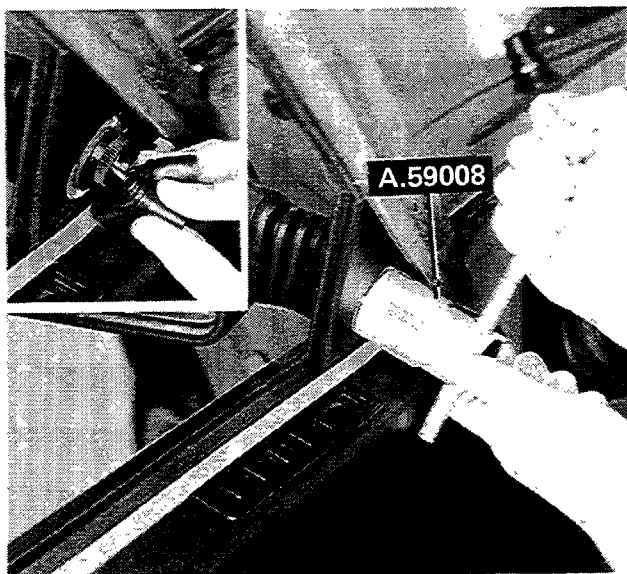

Removing – refitting external rear view mirror



Removing – refitting interior door safety device and handle.

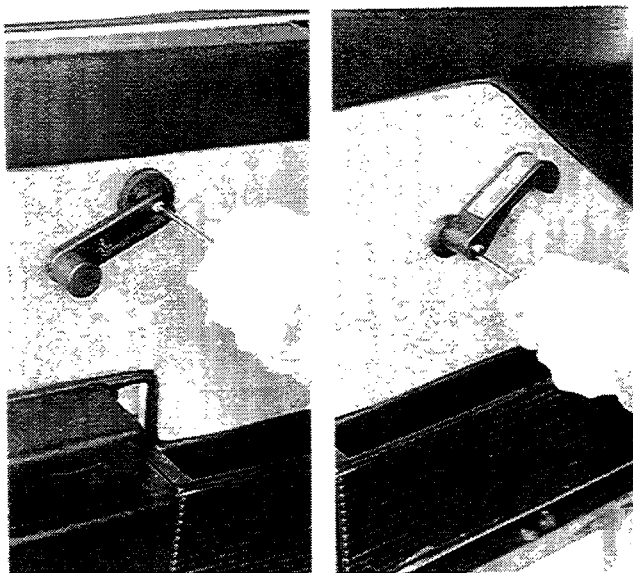

Removing – refitting window winder and door opening lever.

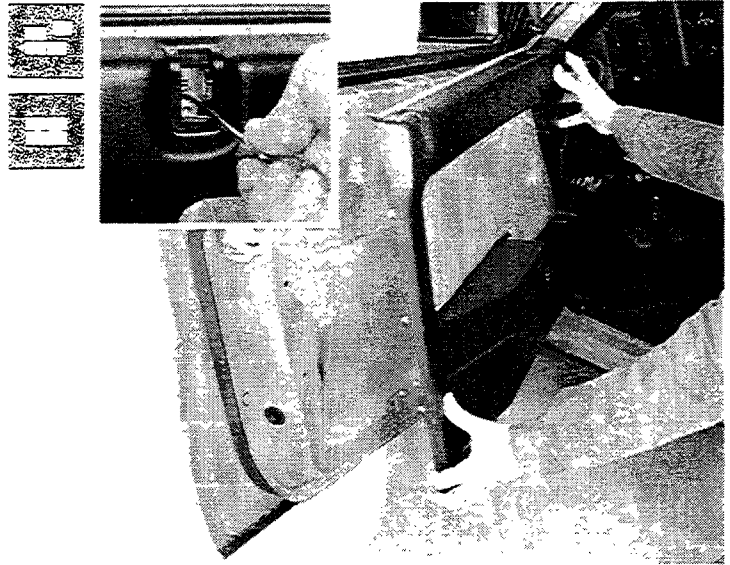

Removing – refitting door panel

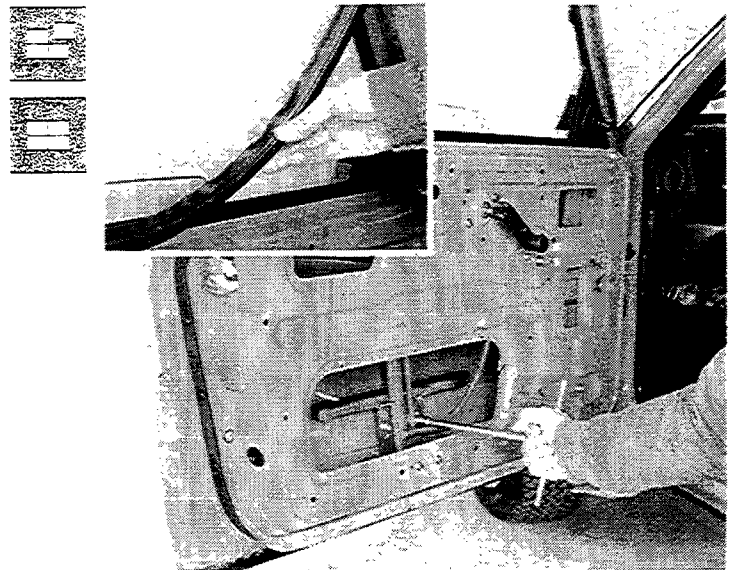

Removing – refitting window glass from window winder device

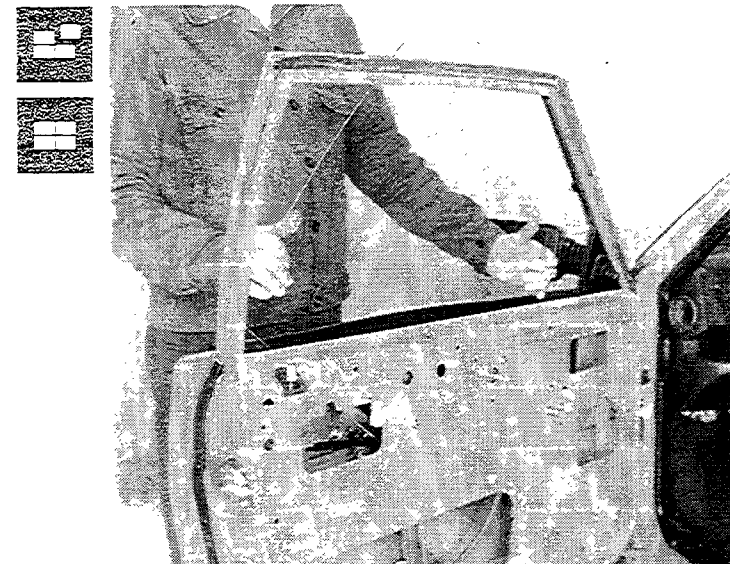

Removing – refitting window glass from door.

**70.**

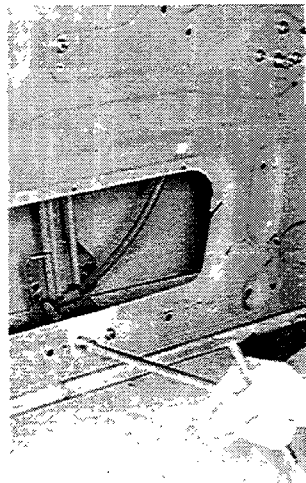
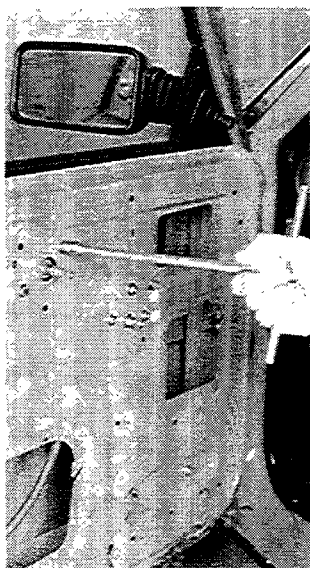

Detaching - reattaching window winder device

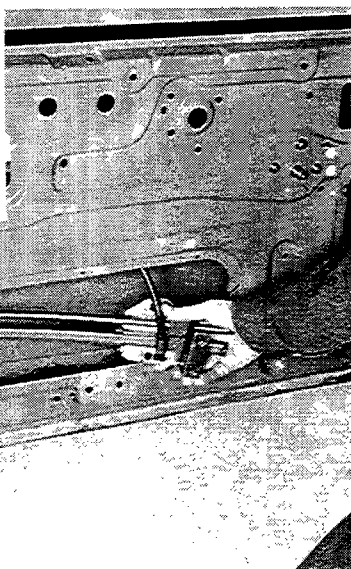
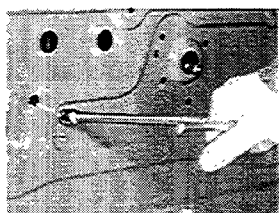

Removing - refitting window winder device from door

**Window winder device components**

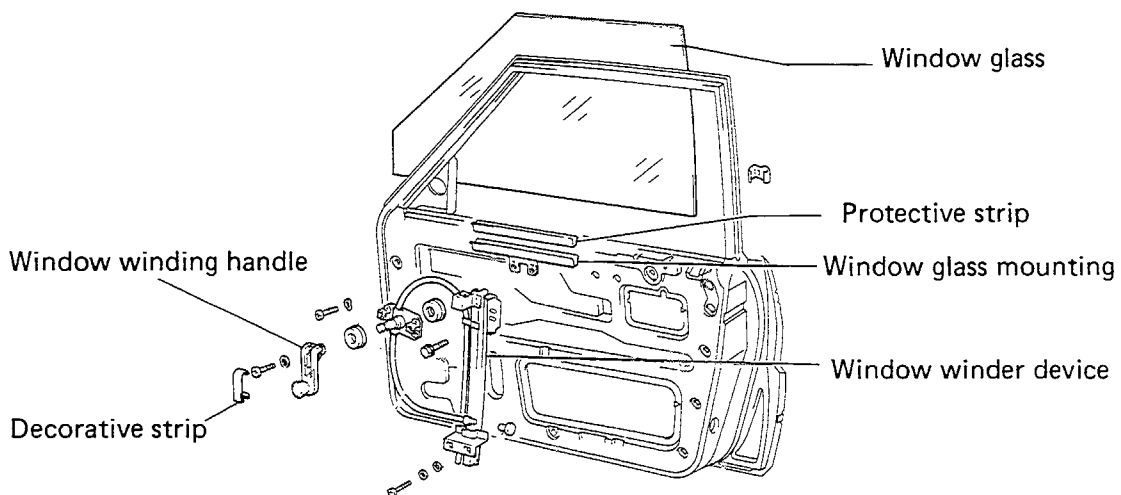



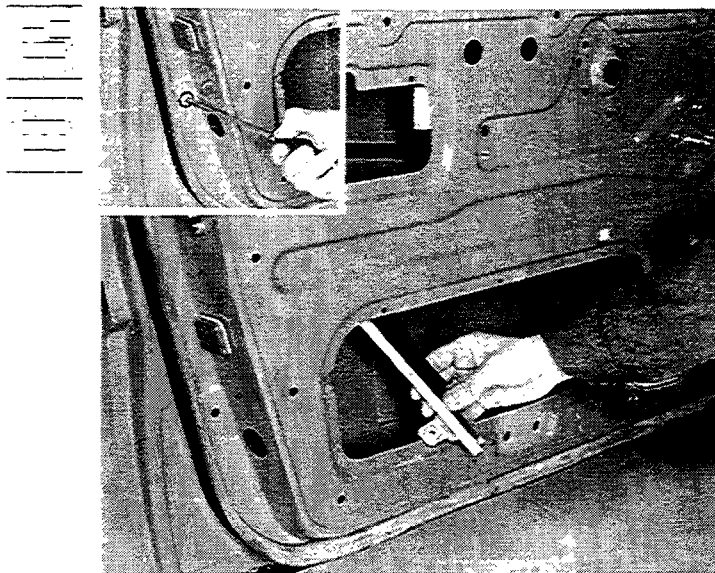

Removing - refitting window glass rear guide channel

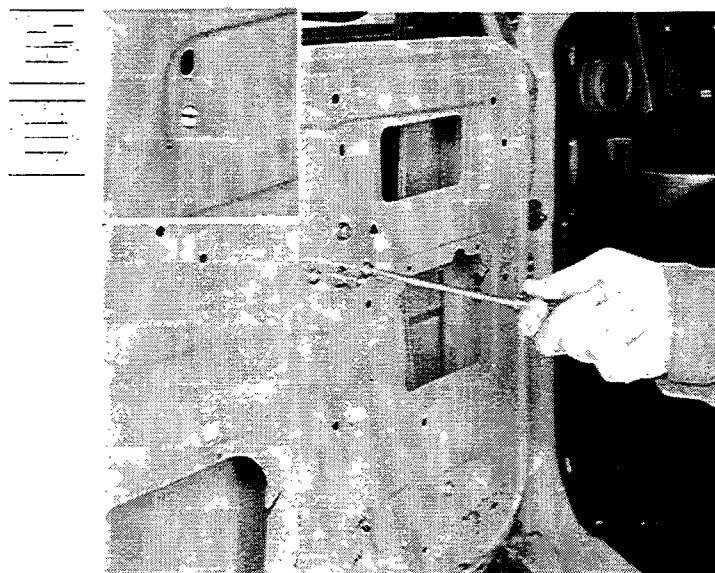

Removing - refitting door opening control

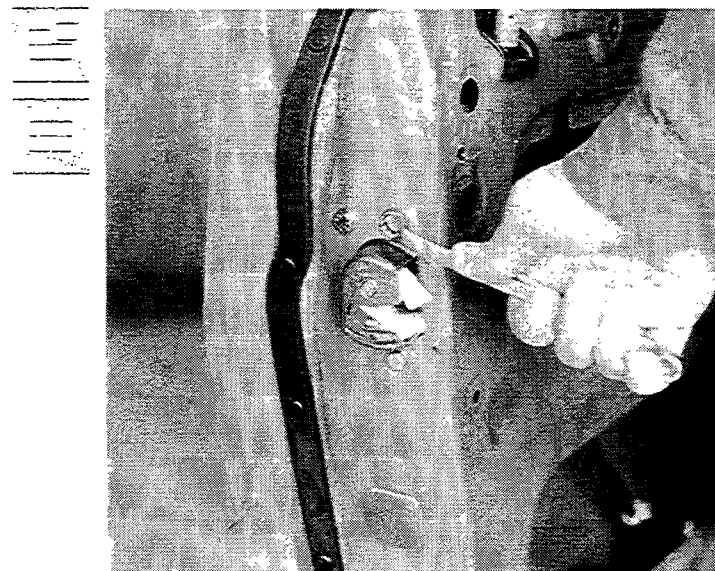

Removing - refitting lock

Front door lock components

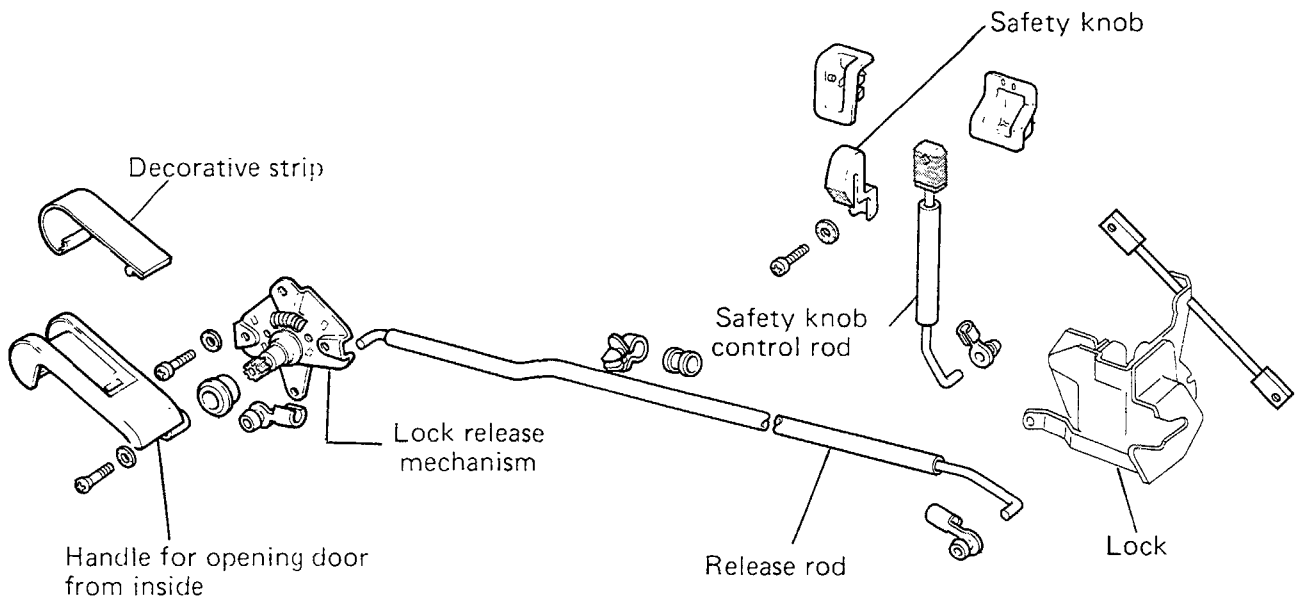

Rear door lock components

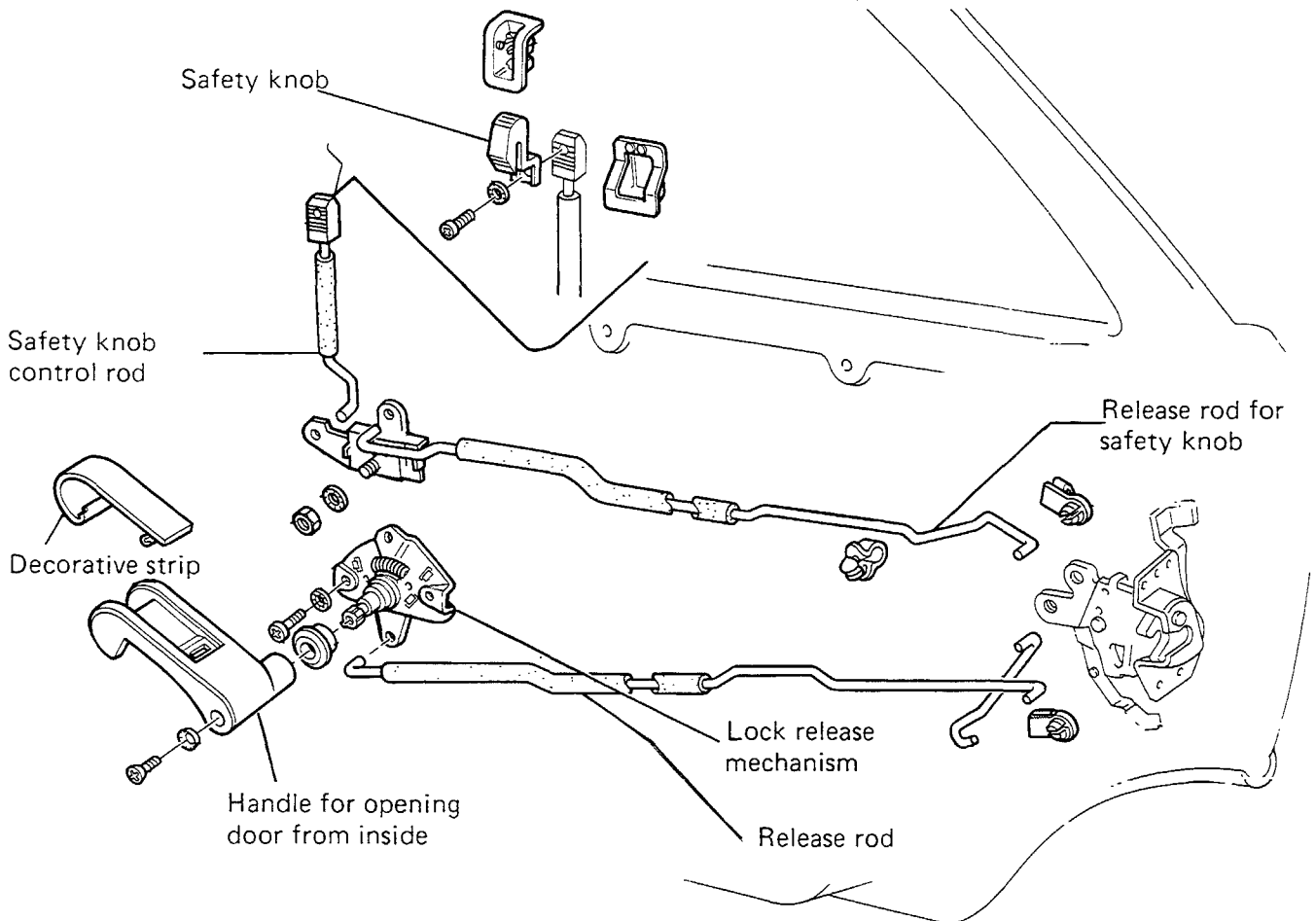

Front door lock components

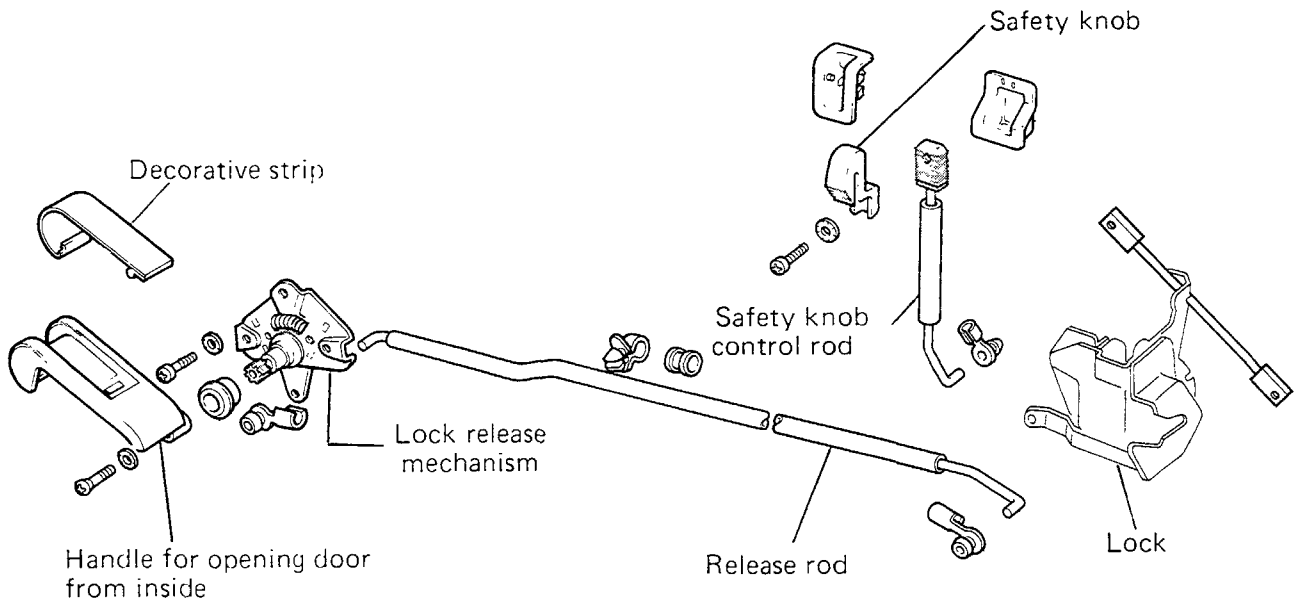

Rear door lock components

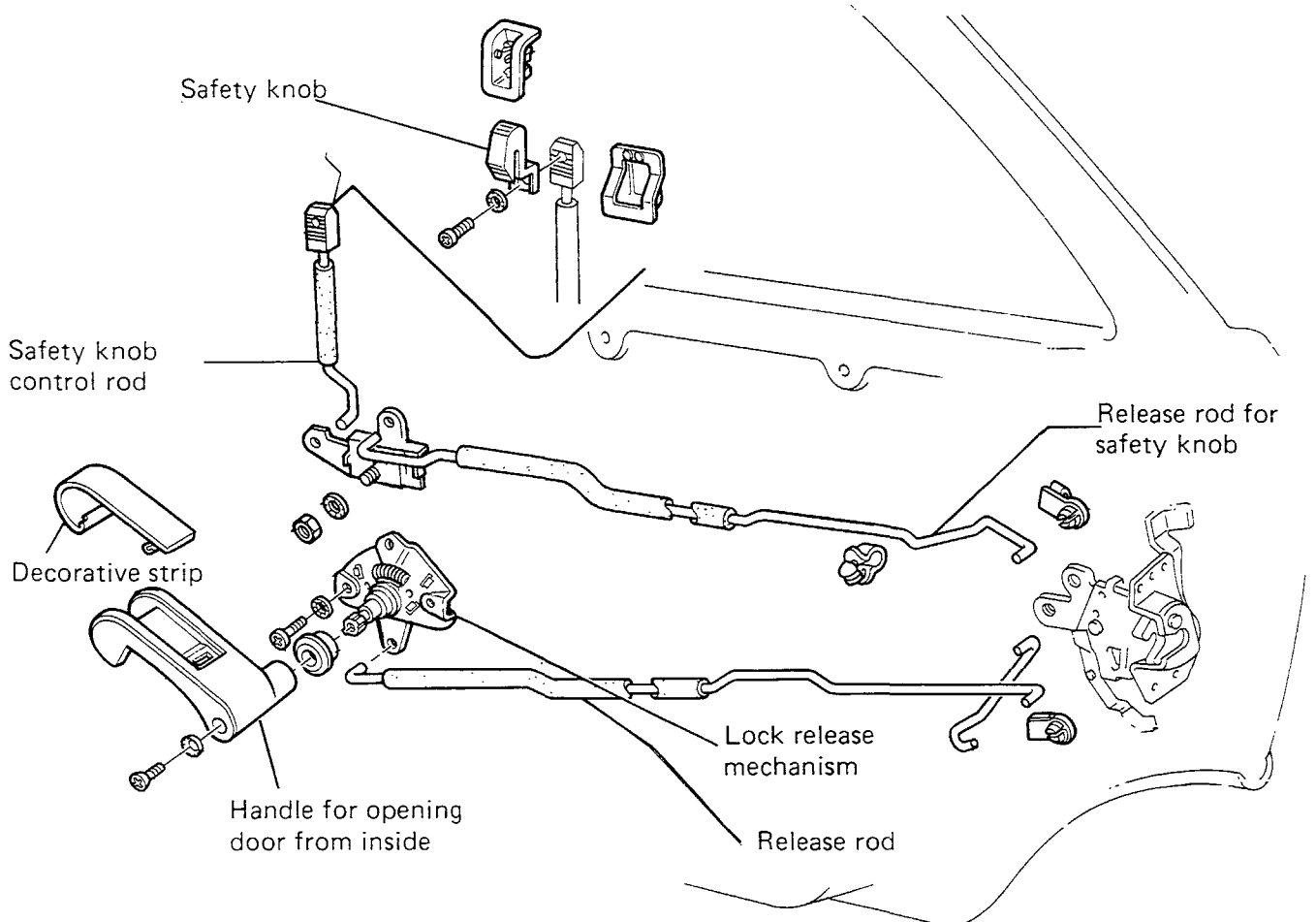



**70.**

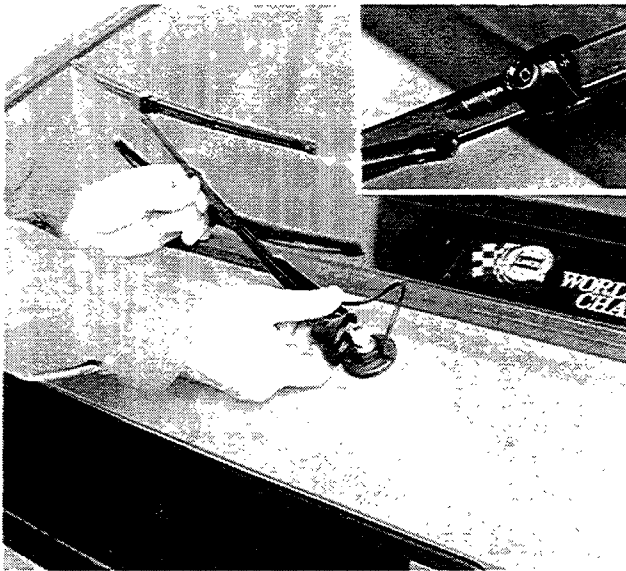

HATCHBACK

Removing - refitting wiper arm complete with blade

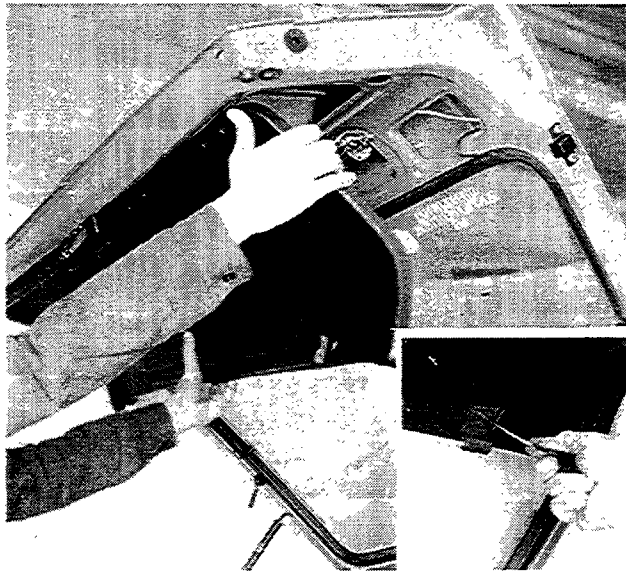

Removing - refitting internal cover

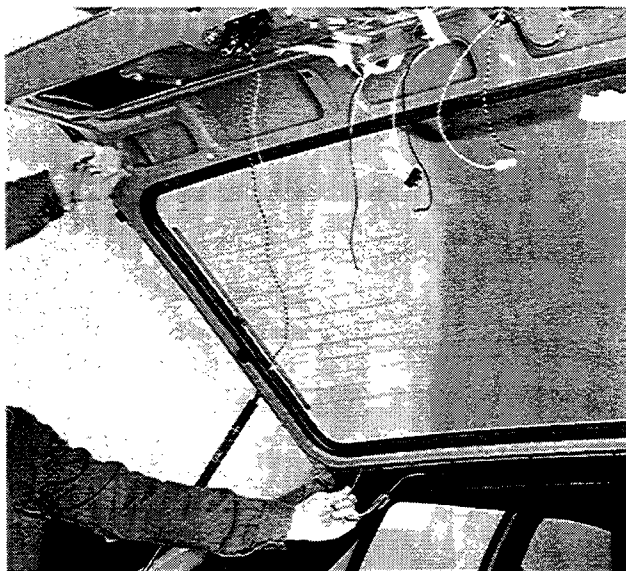

Removing - refitting electrical cables from hatchback

Removing - refitting hatchback support/controlled closing arm

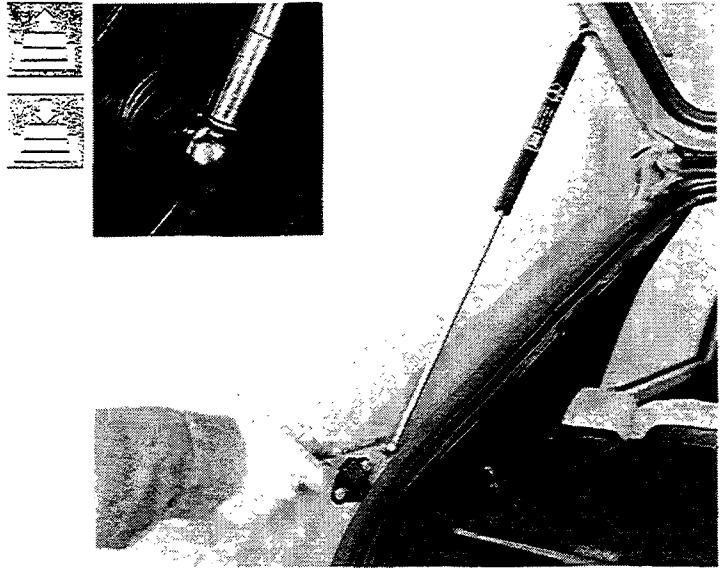

Removing - refitting

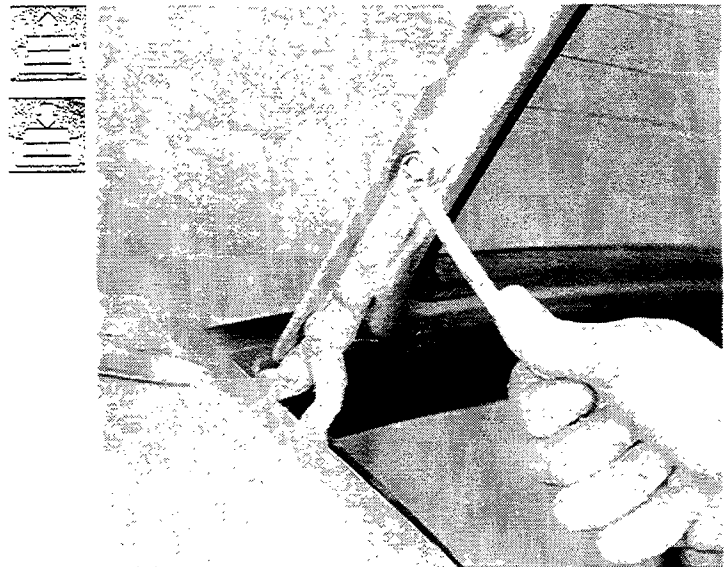

Adjusting positioning of hatchback

**NOTE** *Adjusting the positioning of the hatchback is done by making appropriate adjustments to the securing bolts. Also check that when the hatchback is closed the catch projections shown in the inset are in the lowered position; if not, place suitable shims between them and the body shell.*

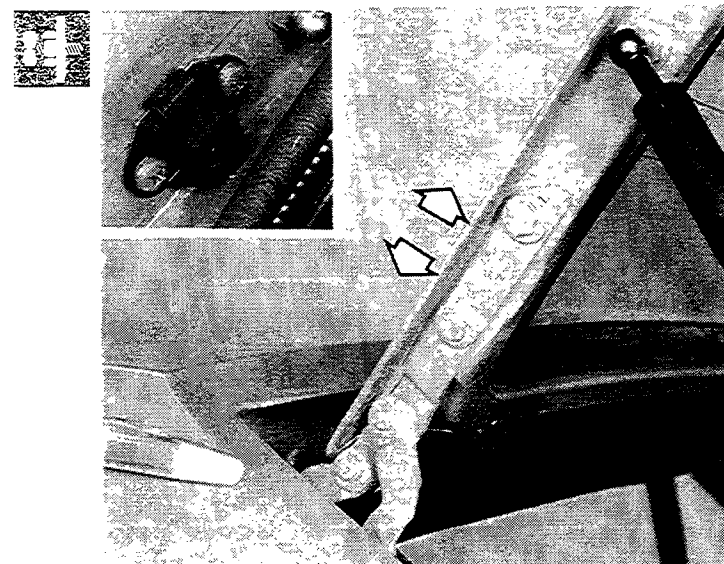

**70.**

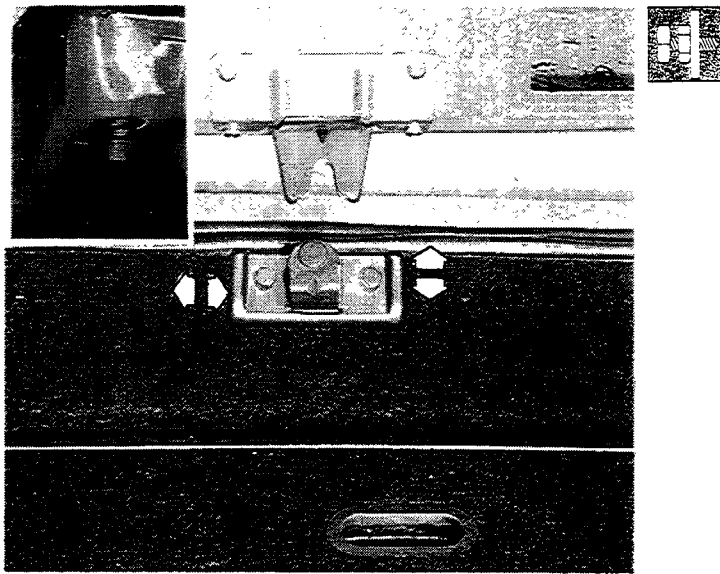

**Adjusting lock striker**

To adjust the hatchback lock move the striker in the direction of the arrows as appropriate. If the hatchback closes properly but it is either too far out or too far in with respect to other parts with which it should line up, adjust the rubber blocks accordingly.

**Hatchback components**

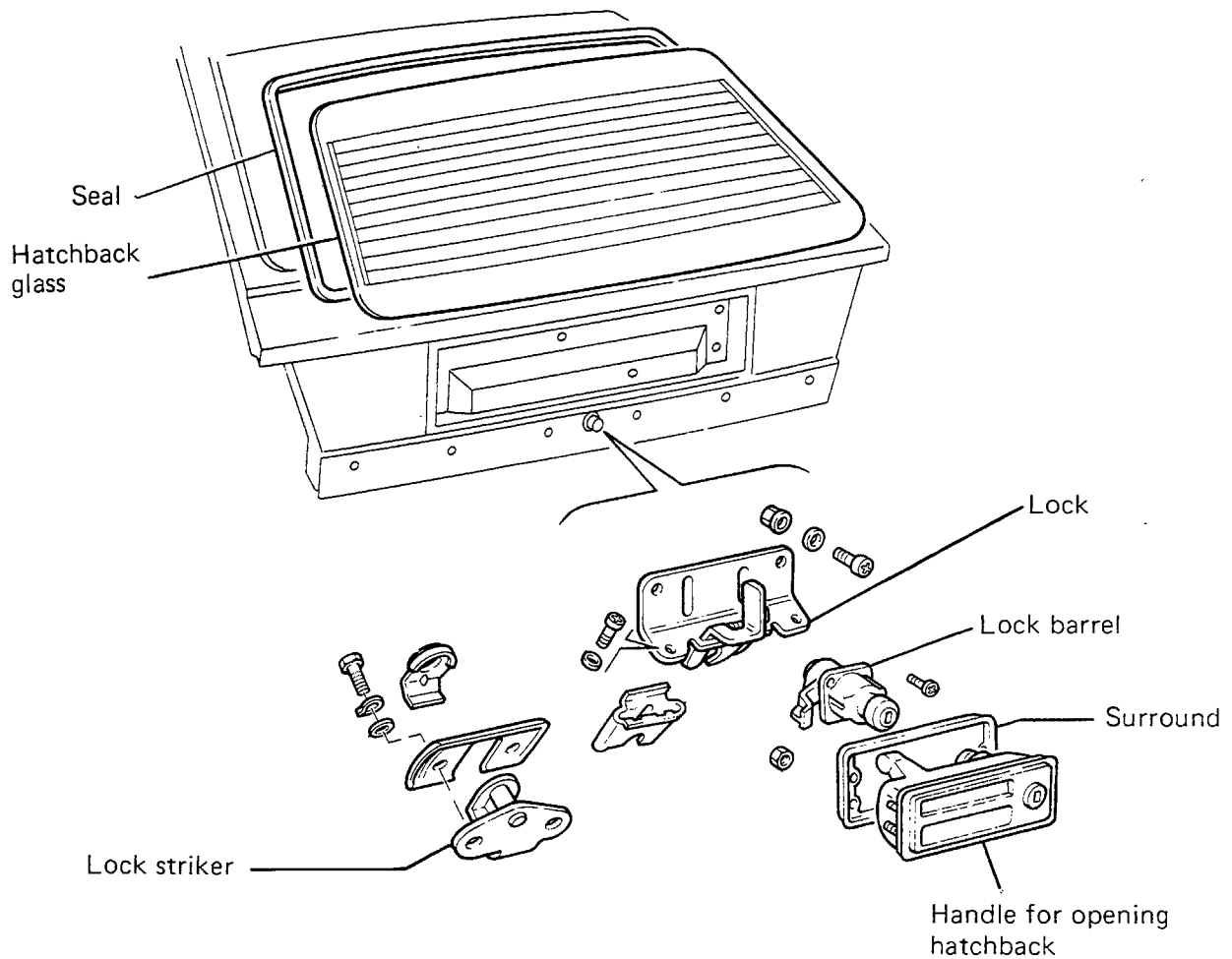

FRONT BUMPER

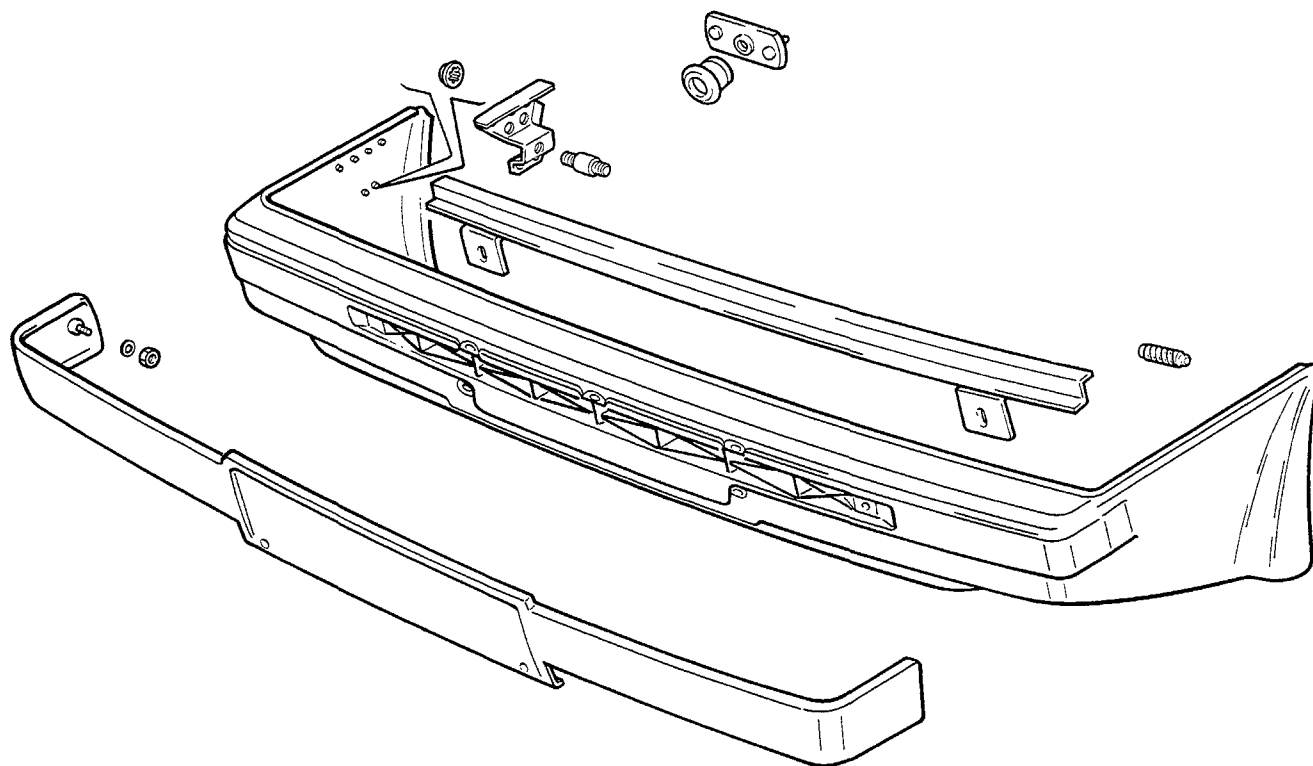

Fixing components

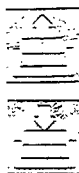

Removing - refitting

The arrows show the bolts for fixing the bumper to the body shell

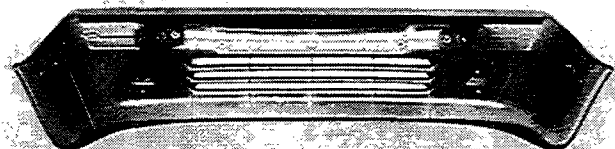

**70.**

**REAR BUMPER**

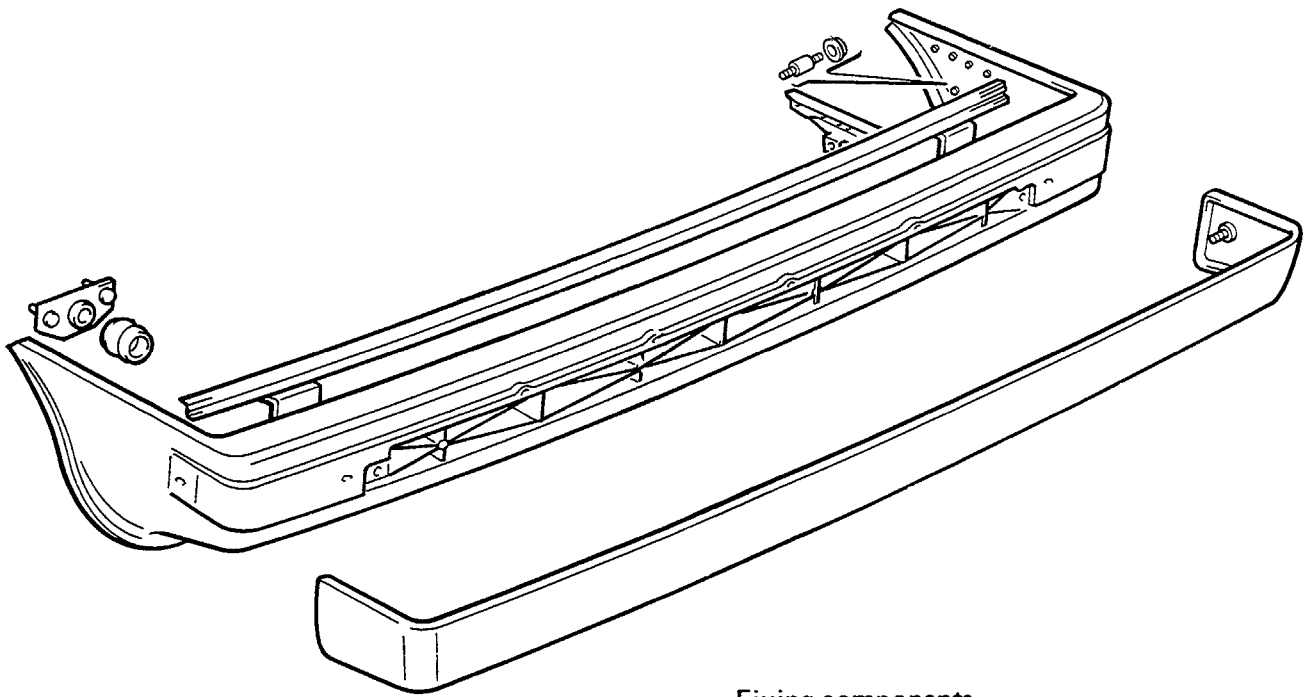

**Fixing components**

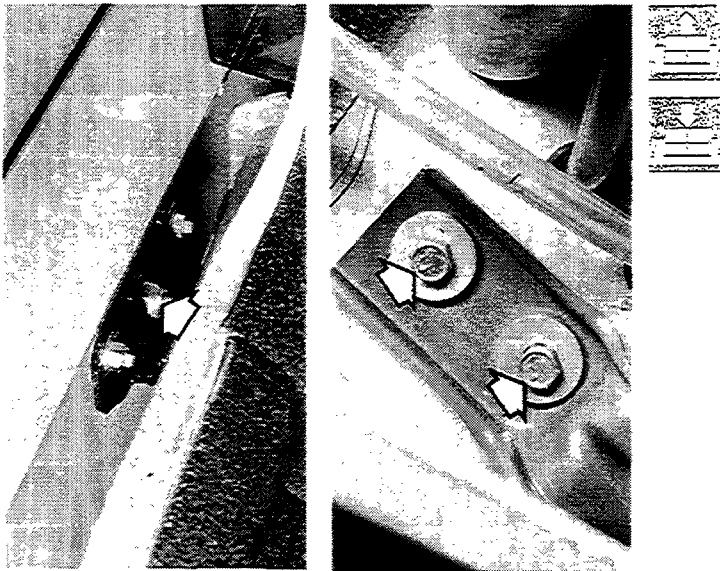

**Removing - refitting**

The arrows show the bolts for fixing the bumper to the body shell

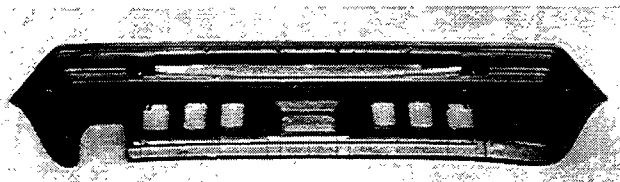

FRONT SEATS

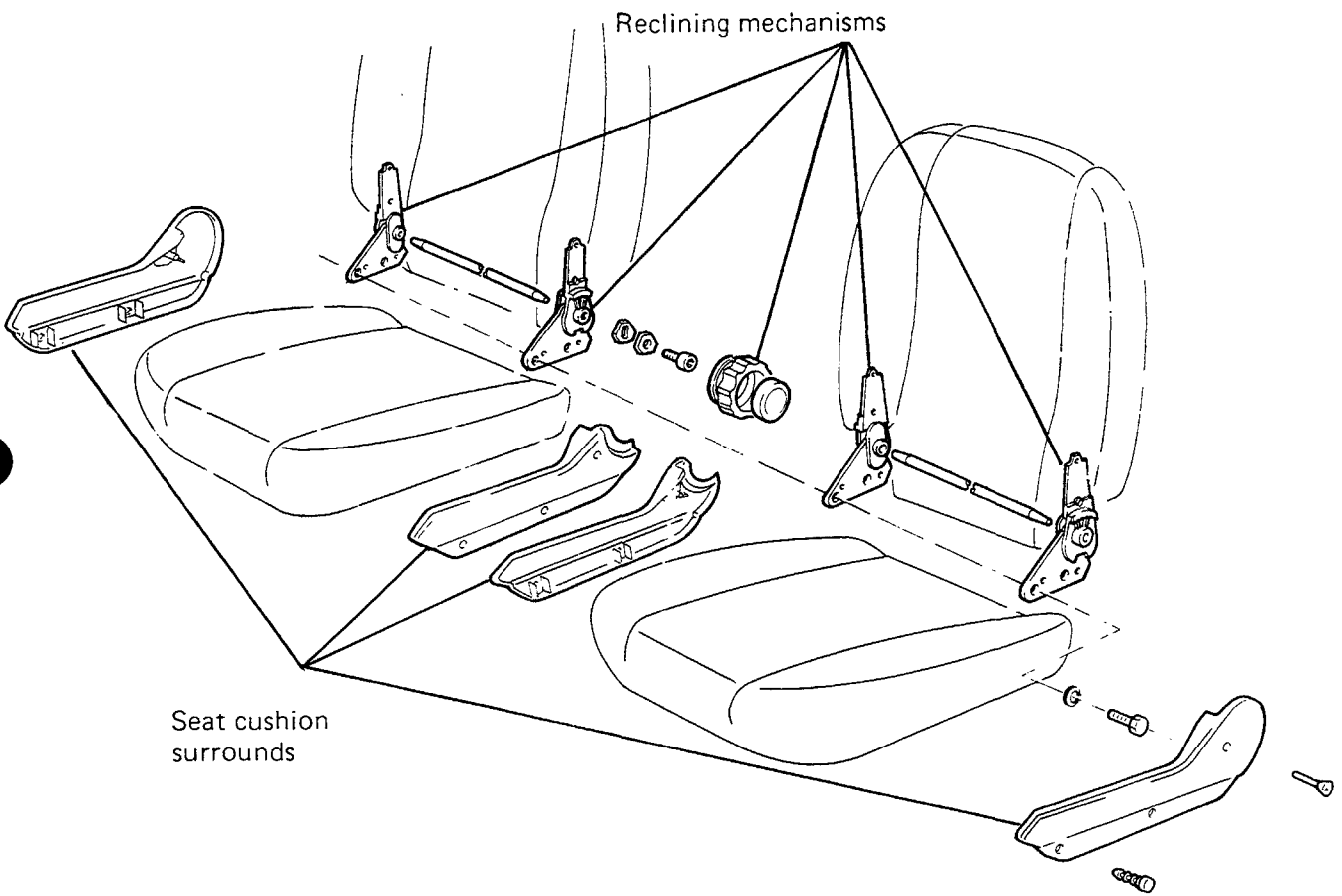

REAR SEATS

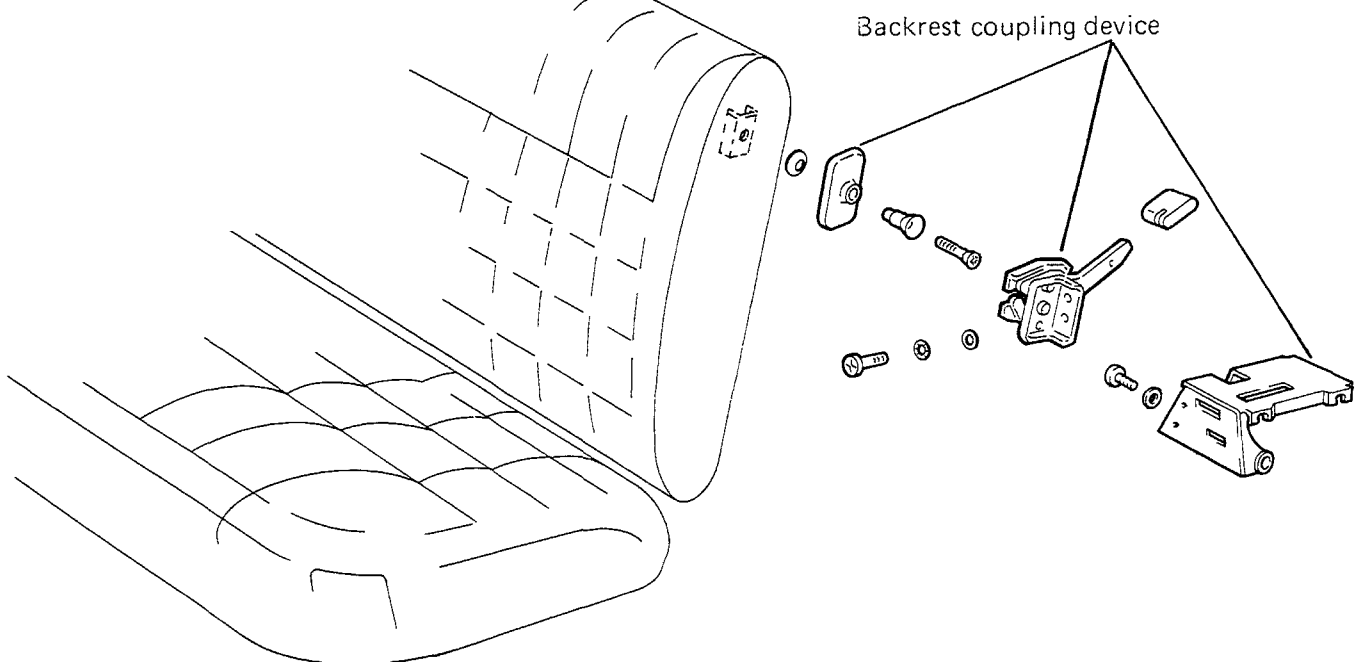

**70.**

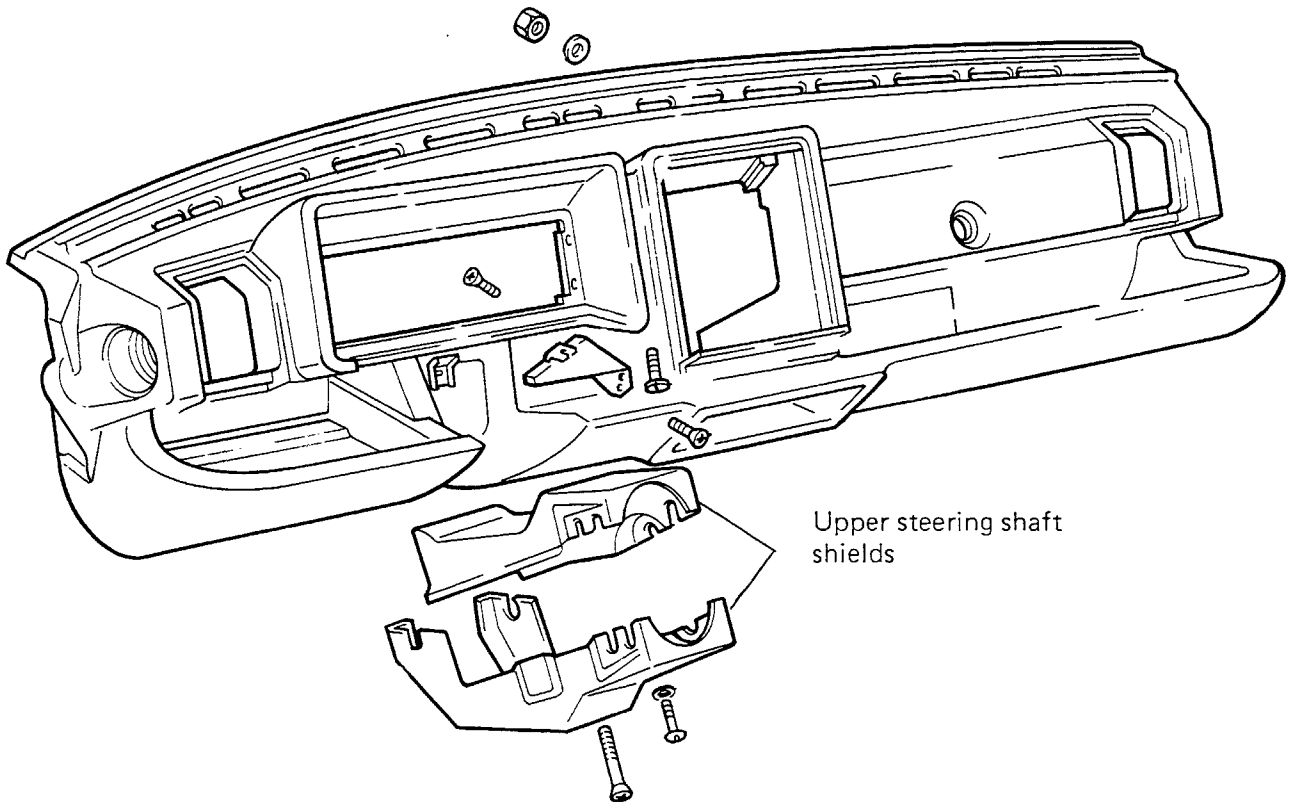
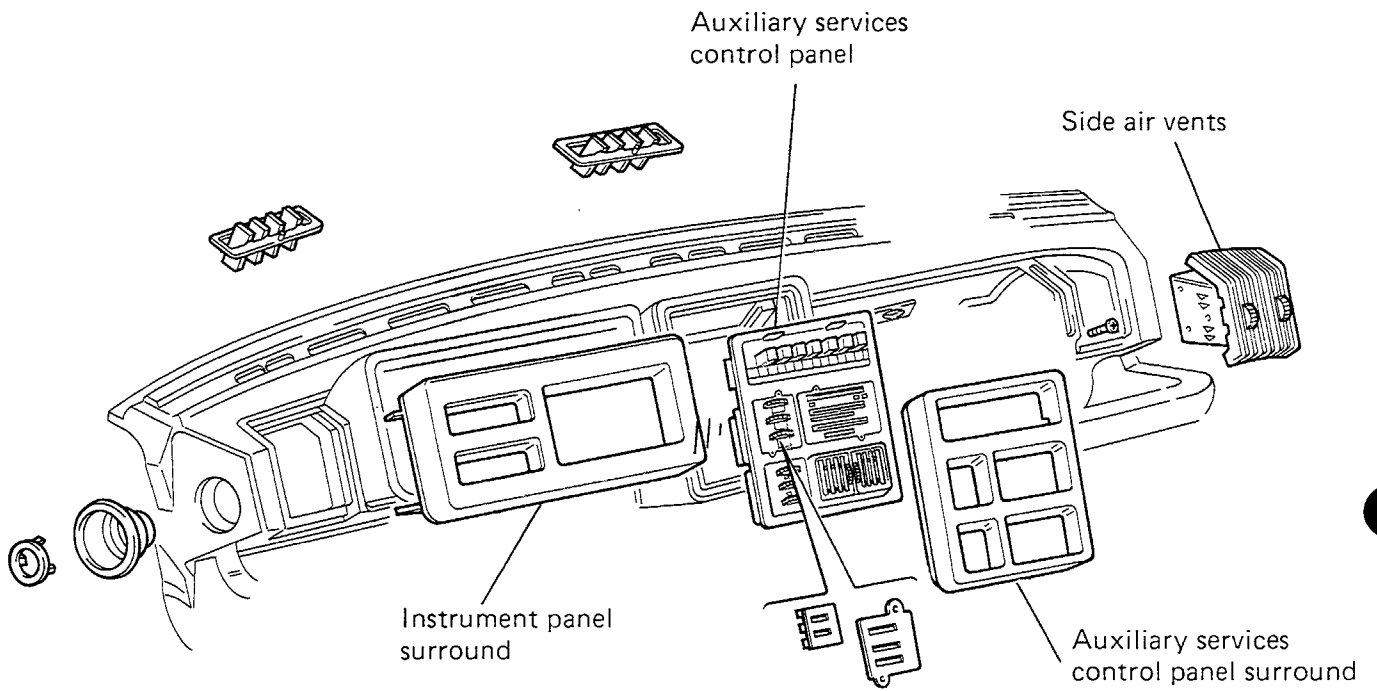

## REPLACING OUTER DOOR SKIN

## View of a damaged front lefthand side door

Using a disk grinding wheel, grind all the way round the perimeter of the outer door panel (as shown by the lines marked A) until it becomes detached from the edge which is folded over (carry out this operation carefully so as not to cut into the framework of the door itself).

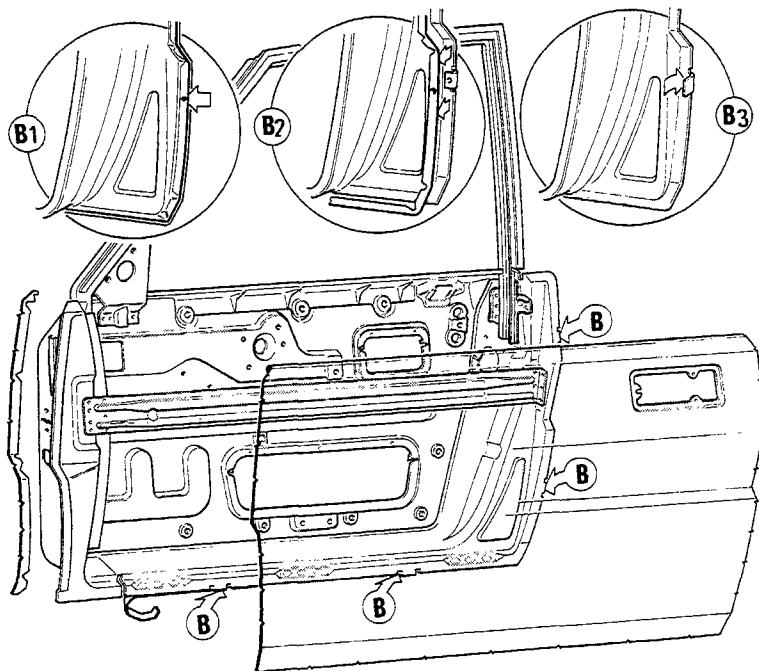
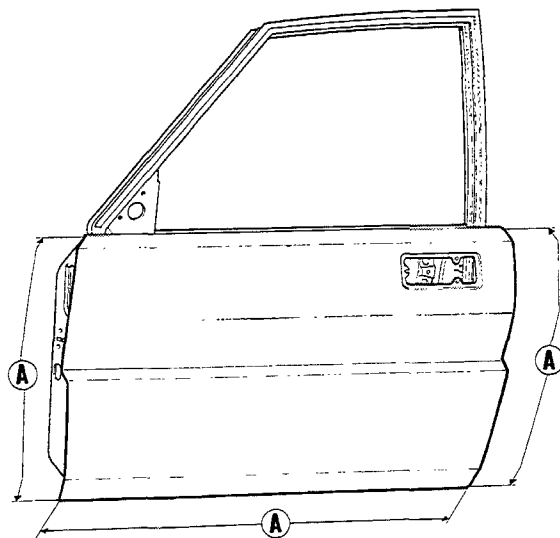

Remove the outer panel, detach the points where the fins, marked B, are spot welded (B<sub>1</sub>), remove the scraps of sheet panel from the framework (B<sub>2</sub>) and fold the fins through 90° (B<sub>3</sub>).

Straighten and grind the welding edges of the door frame and protect them with a zinc-based anti-rust agent. Remove the coat of protective paint from the replacement door panels at those points where it is anticipated that it will be welded to the door frame.

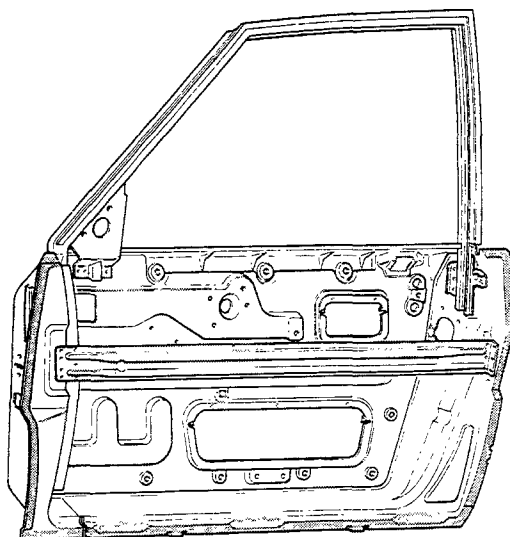



**70.**

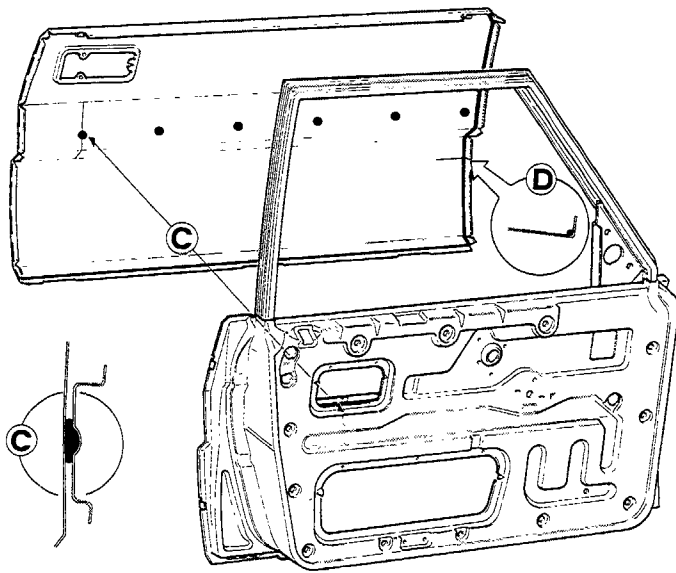

Apply hot thermosetting adhesive mastic to the panel at the points shown by the reference C. Apply structural adhesive in the areas shown by the black lines and by the cross section marked D.

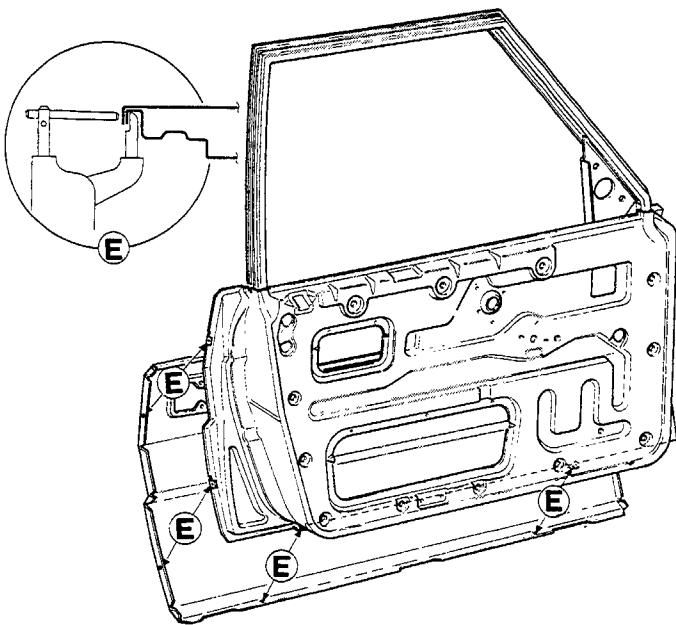

Weld the outer panel to the fins on the framework marked E using an electric spot welder.

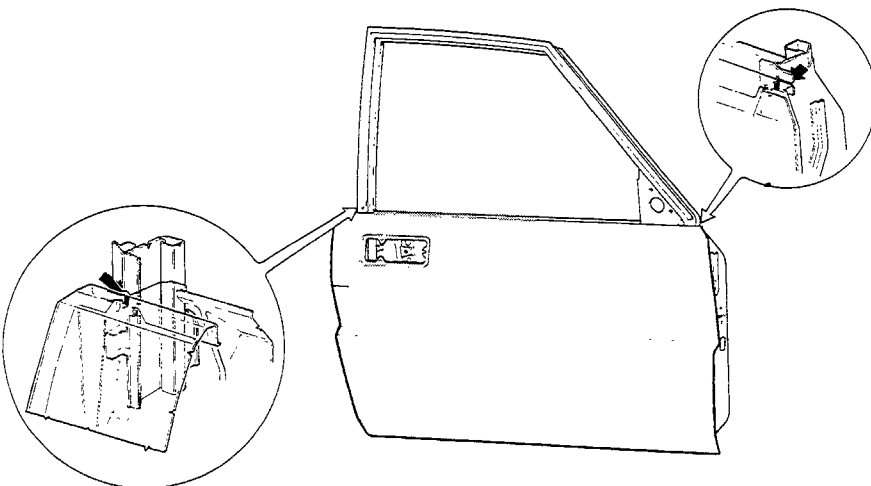

Weld the outer panel to the framework using an inert gas electrode at the 2 points shown by the black arrows.

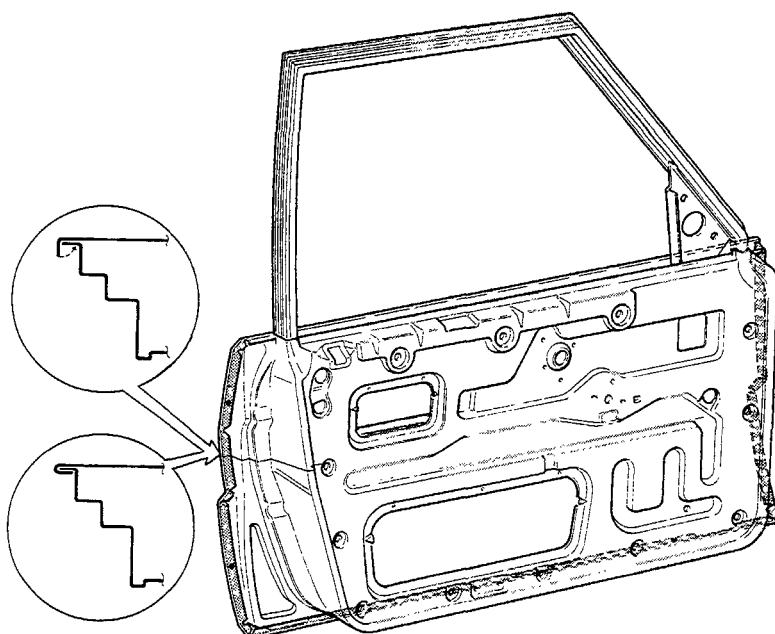

Fold the edge of the outer panel over the framework of the door using a hammer and block.

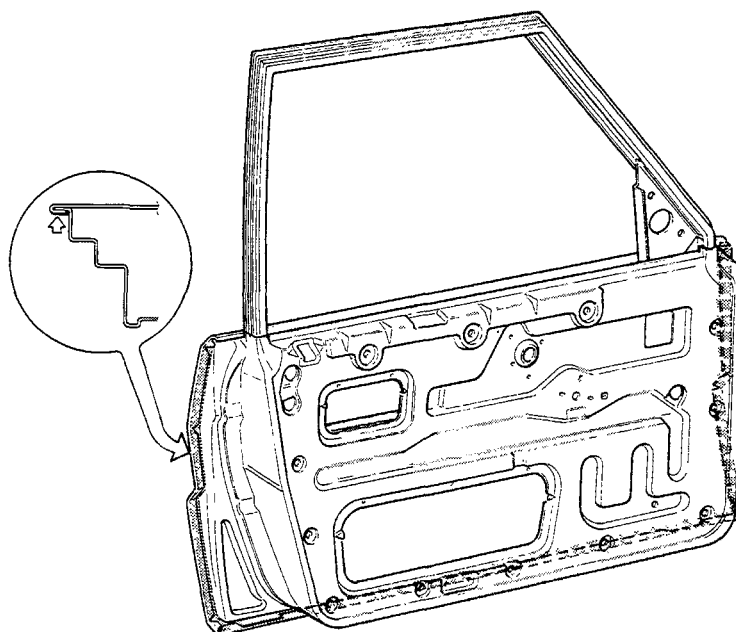

Complete the operation by sealing the shaded areas: this is done by smearing them with hot-setting sealant for interior use.

**70.**

**REPLACING FRONT SECTION, FRONT CROSSMEMBER AND MOUNTINGS FOR FIXING BUMPER**

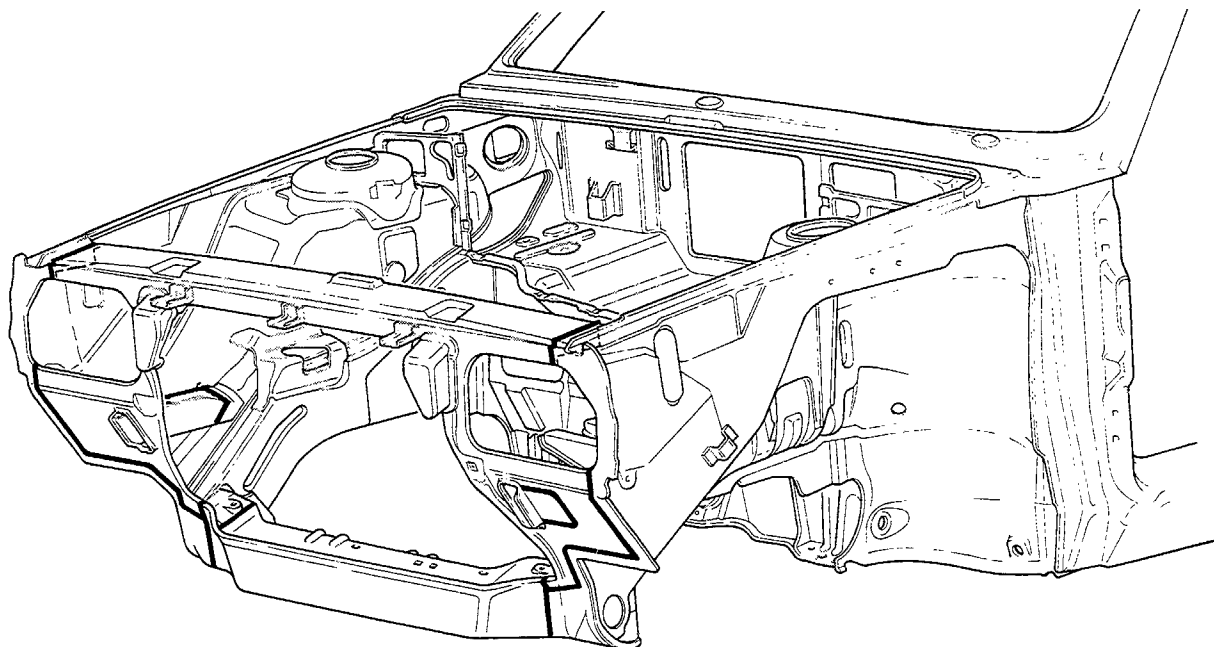

The lines show where to cut, using a pneumatic hacksaw, in order to remove those parts which are to be replaced.

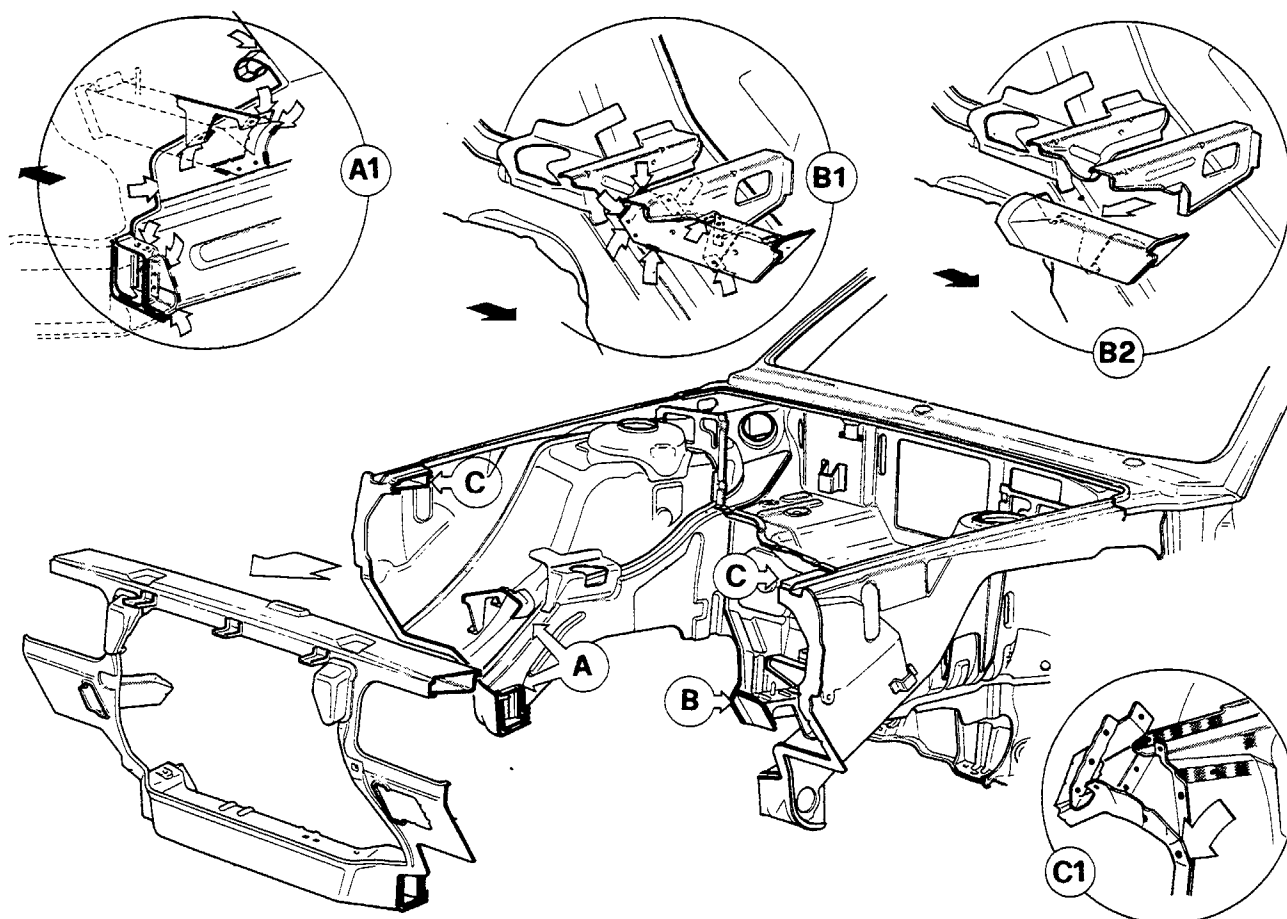

Remove the scraps of sheet metal (shown by the letters A, B and C and in greater magnification by details A<sub>1</sub>, B<sub>1</sub>, B<sub>2</sub> and C<sub>1</sub>) using a milling cutter for detaching joining points, a pneumatic or manual chisel and tongs.

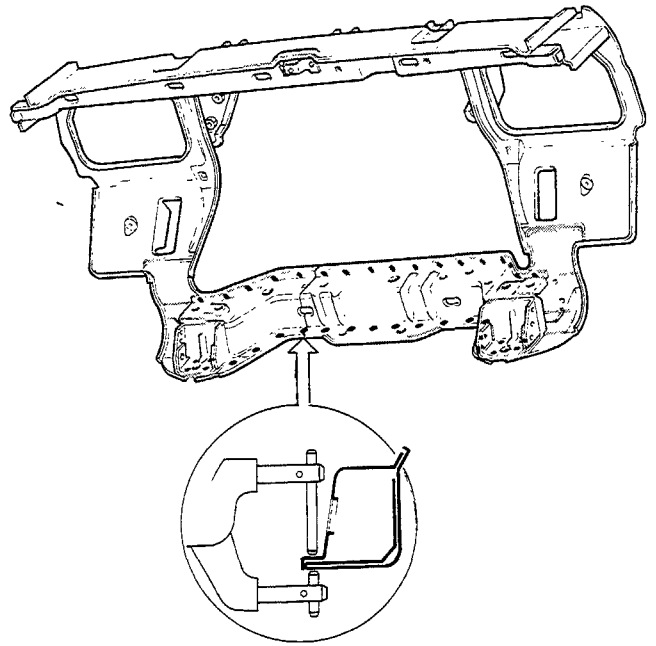
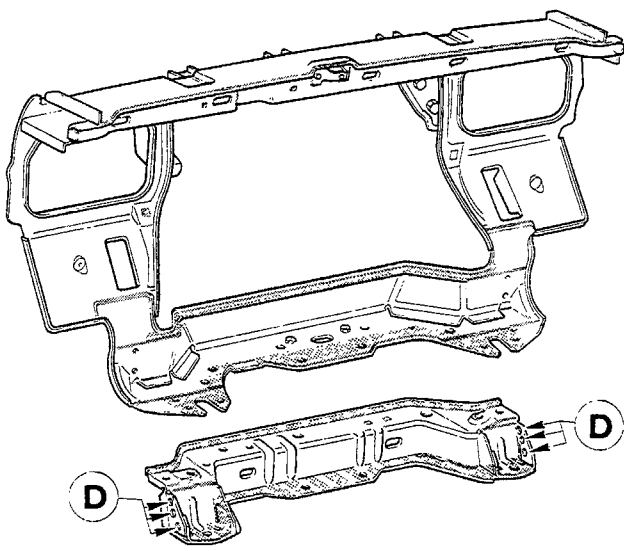

Drill 6 6mm holes in the lower crossmember as shown by reference marks D.  
Grind the shaded welding areas and protect them with a zinc-based anti-rust agent.

Weld the crossmember to the front section using a spot welder.

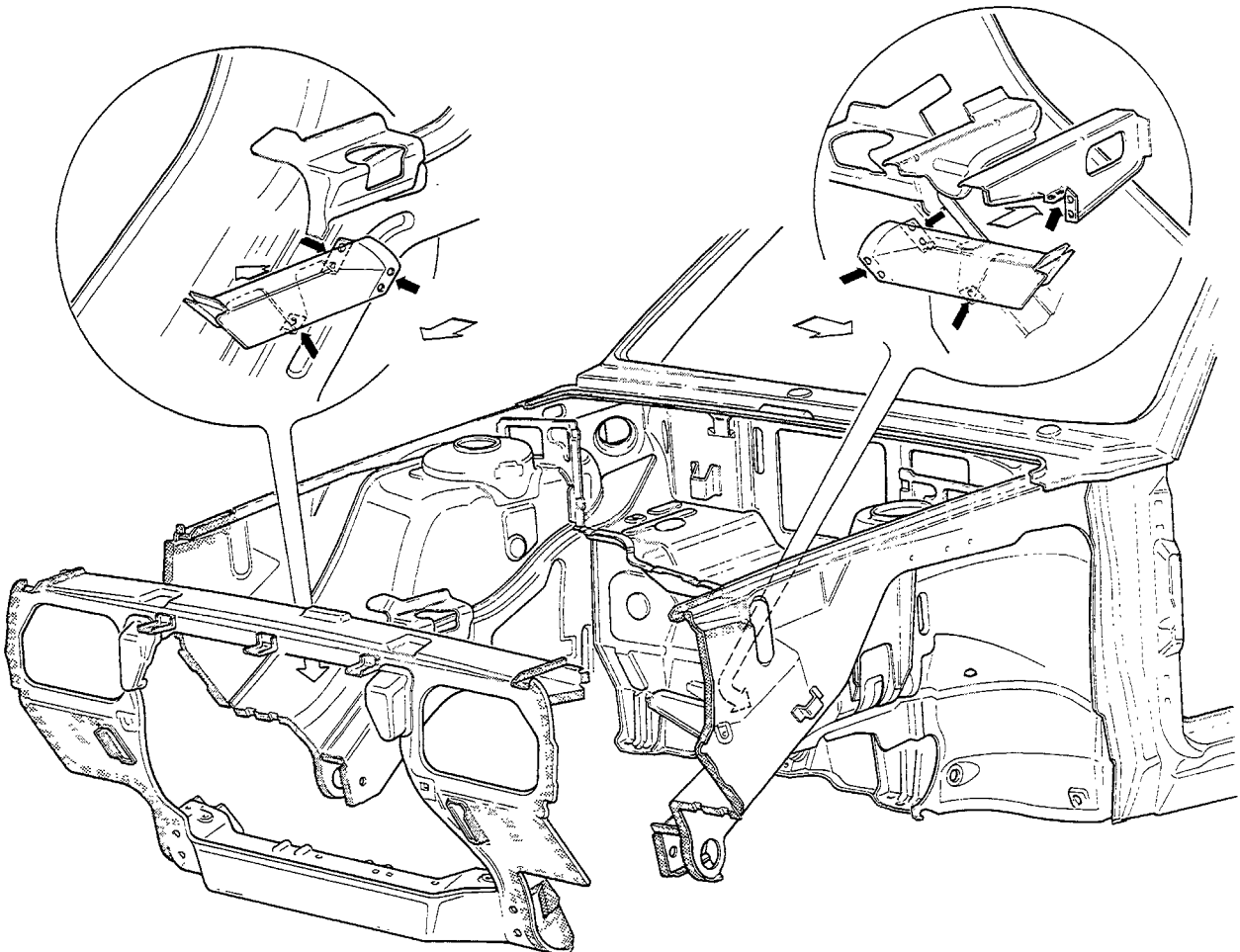

Straighten and grind the welding edges on the body shell, grind the welding edges on the replacement part and protect the shaded welding areas with zinc-coating.  
Drill a series of 6 mm holes in the mountings for fixing the bumper, at the points shown by the arrows.

**70.**

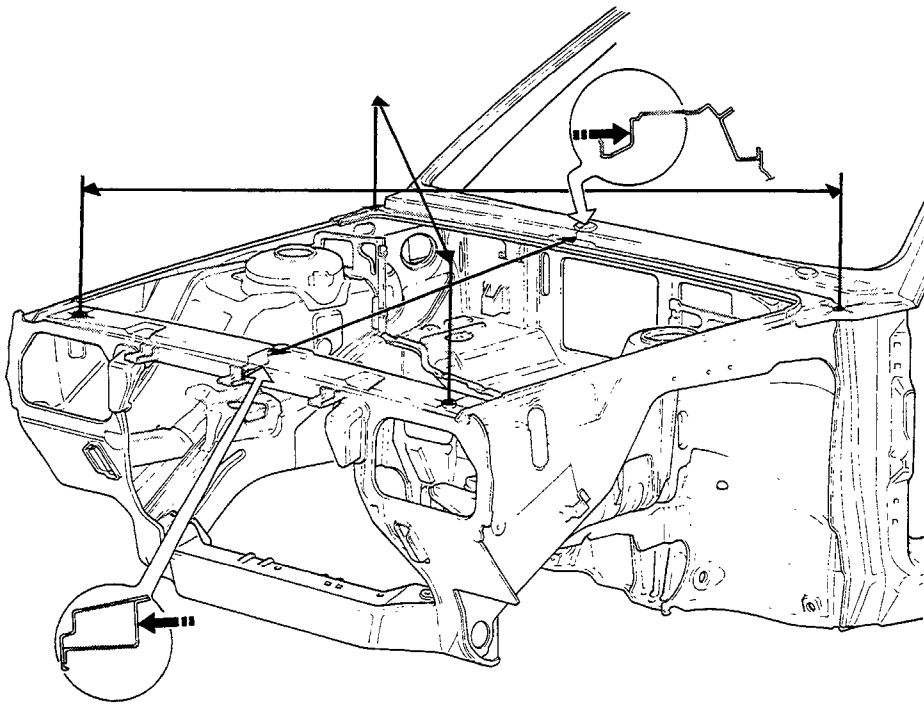

Fit the replacement part in place and fasten it with self-locking pliers, check that the diagonals are of equal length and check the depth of the engine compartment. Provisionally fit the bonnet lid and check that it locks properly

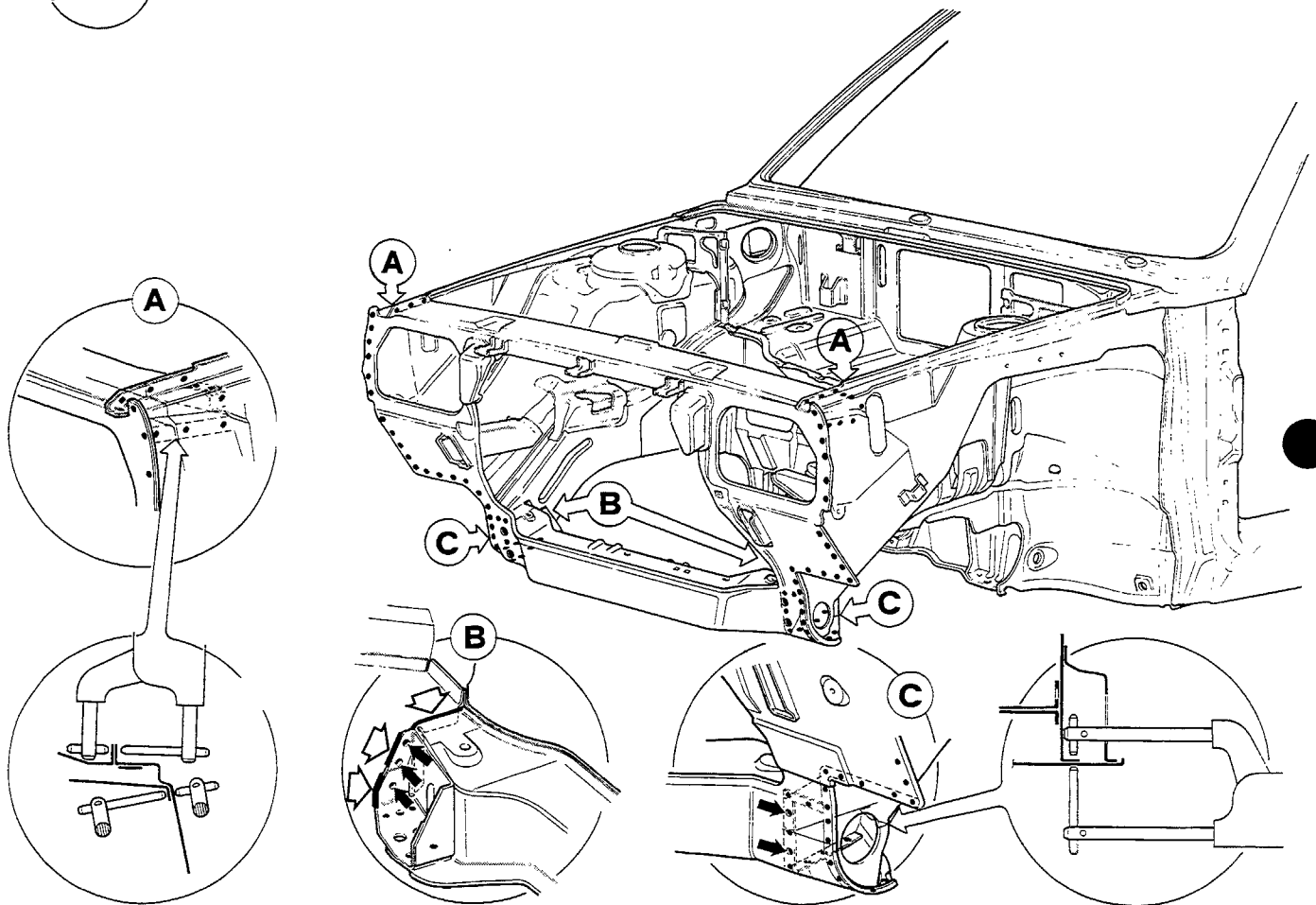

Weld the front section to the wheel arch using a spot welder.  
Weld the front crossmember to the longitudinal members and to the wheel arches filling the holes shown by the black arrows, using an inert gas electrode welder.

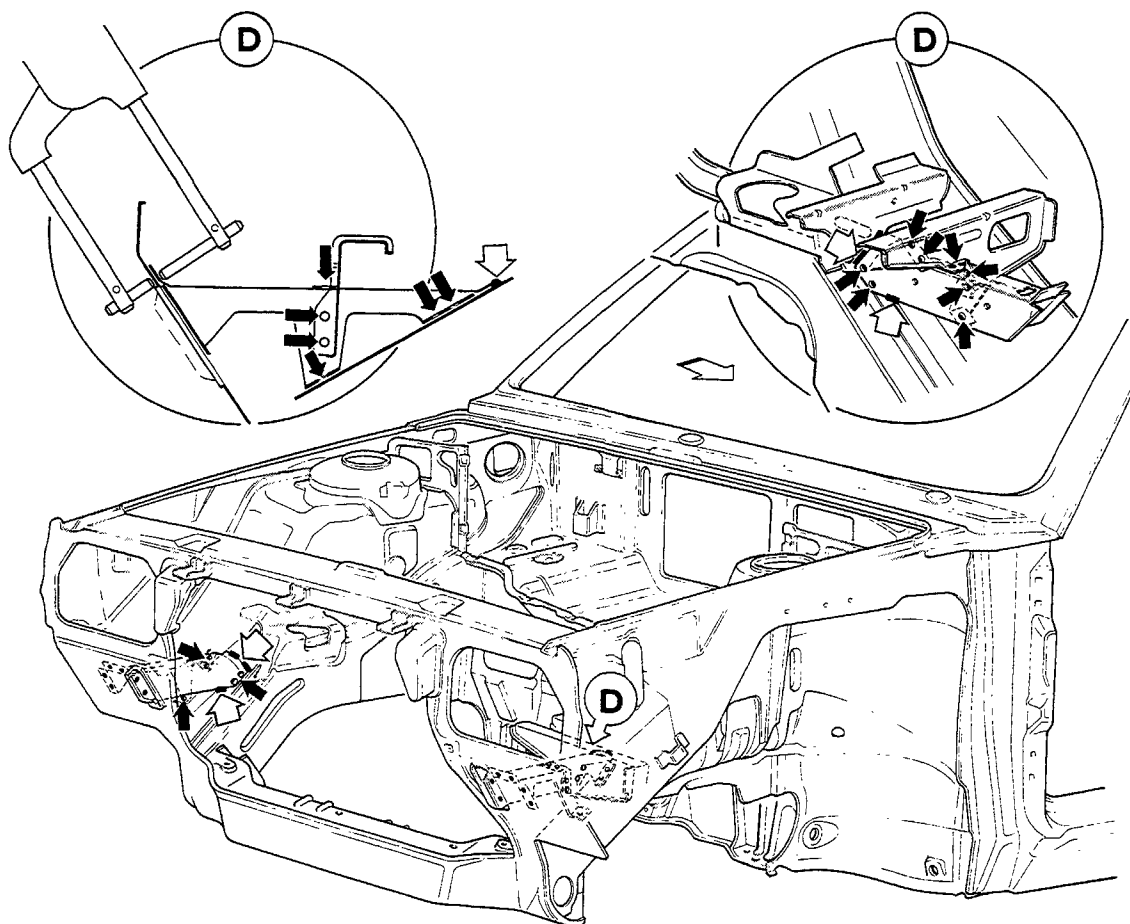

Position the lefthand mounting for fixing the bumper, marked D, and weld it to the side member and to the battery housing bracket filling the holes shown by the black arrows in the two magnified details, marked D, using an inert gas electrode welder.

To make a stronger job of fixing the mounting, carry out inert gas electrode welding where shown by the white arrows in the magnified details marked D.

Continue fixing the mounting by spot welding the areas shown.

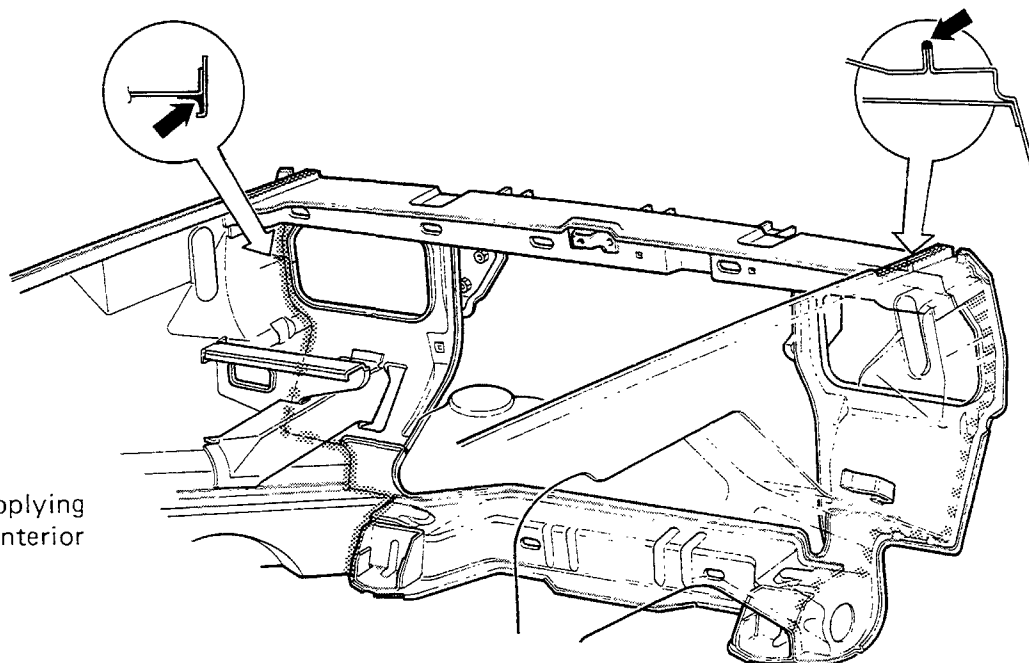

Re-seal the joints by applying hot-setting sealant for interior use in the areas shown.

**70.**

**REPLACING FRONT WING**

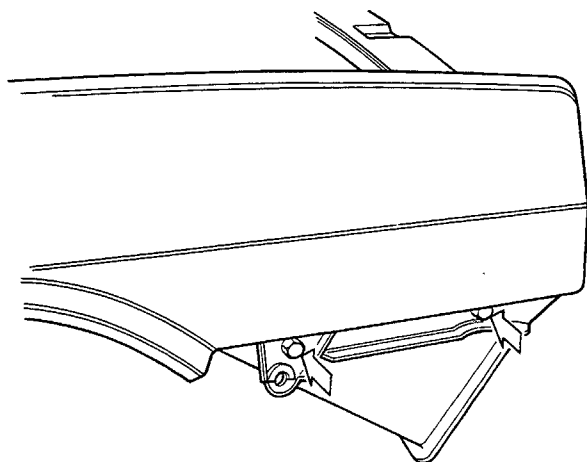
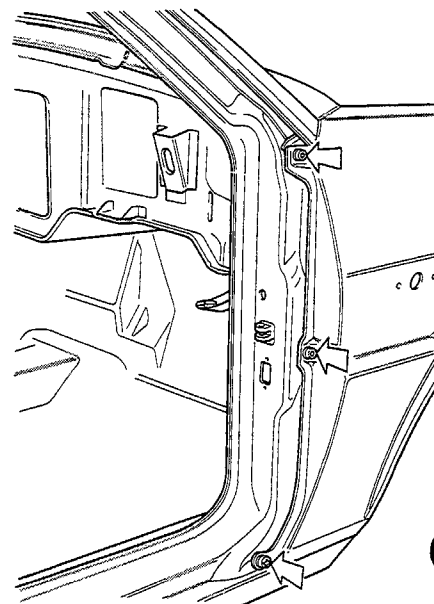
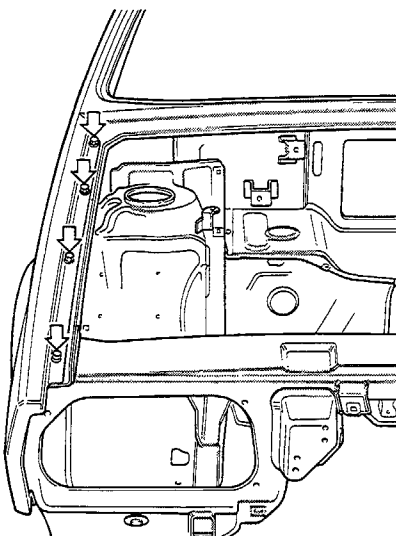
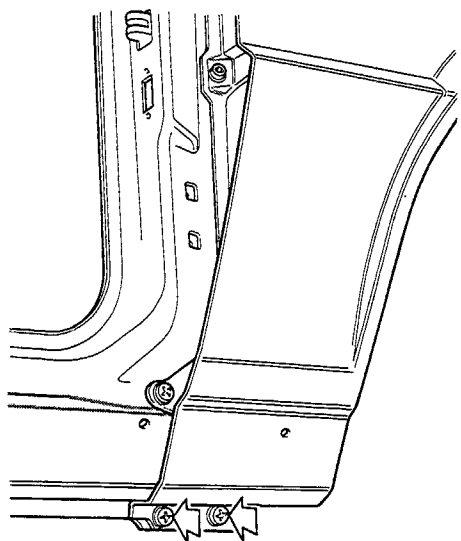

To remove the wing, remove the bolts securing it to the wheel arch, door pillar and door sill.  
The illustrations show where the bolts are located.

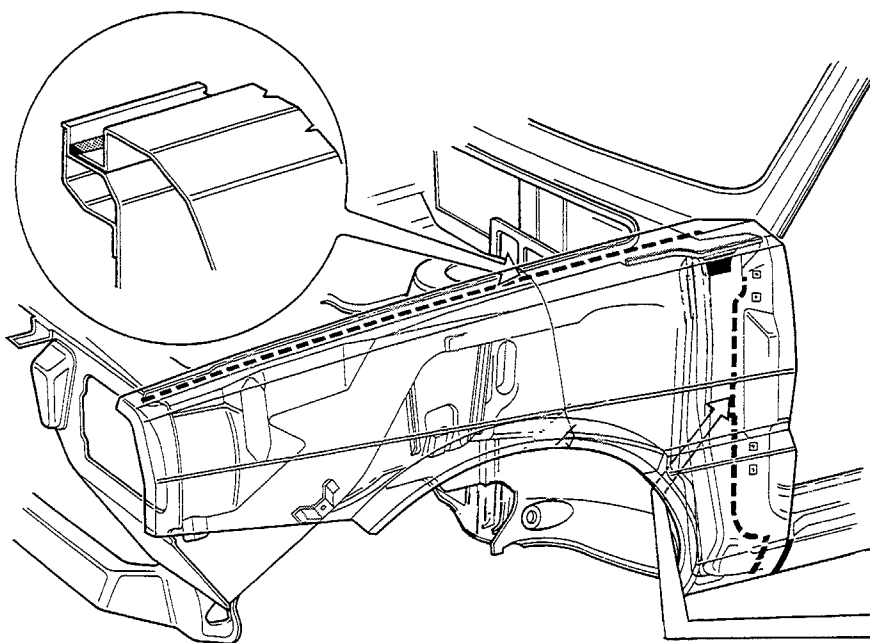

Renew the bead of plastic (Sigilflex) sealant along the joints marked with the broken lines.

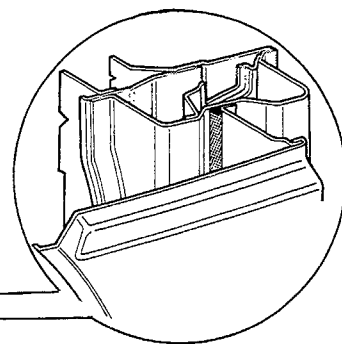

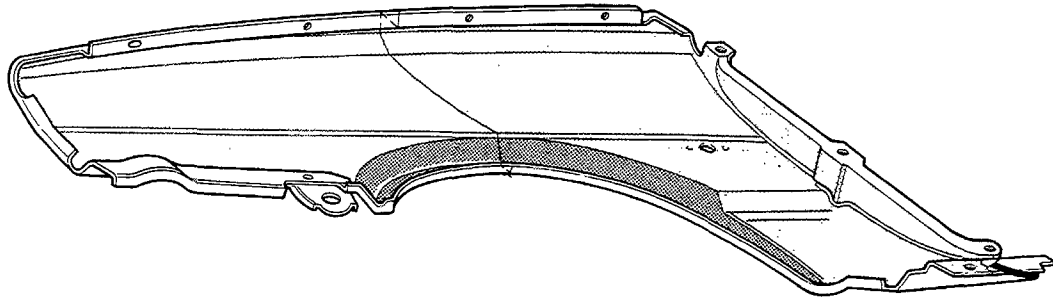

Renew the anti-rust protection and soundproofing on the inside of the wing.

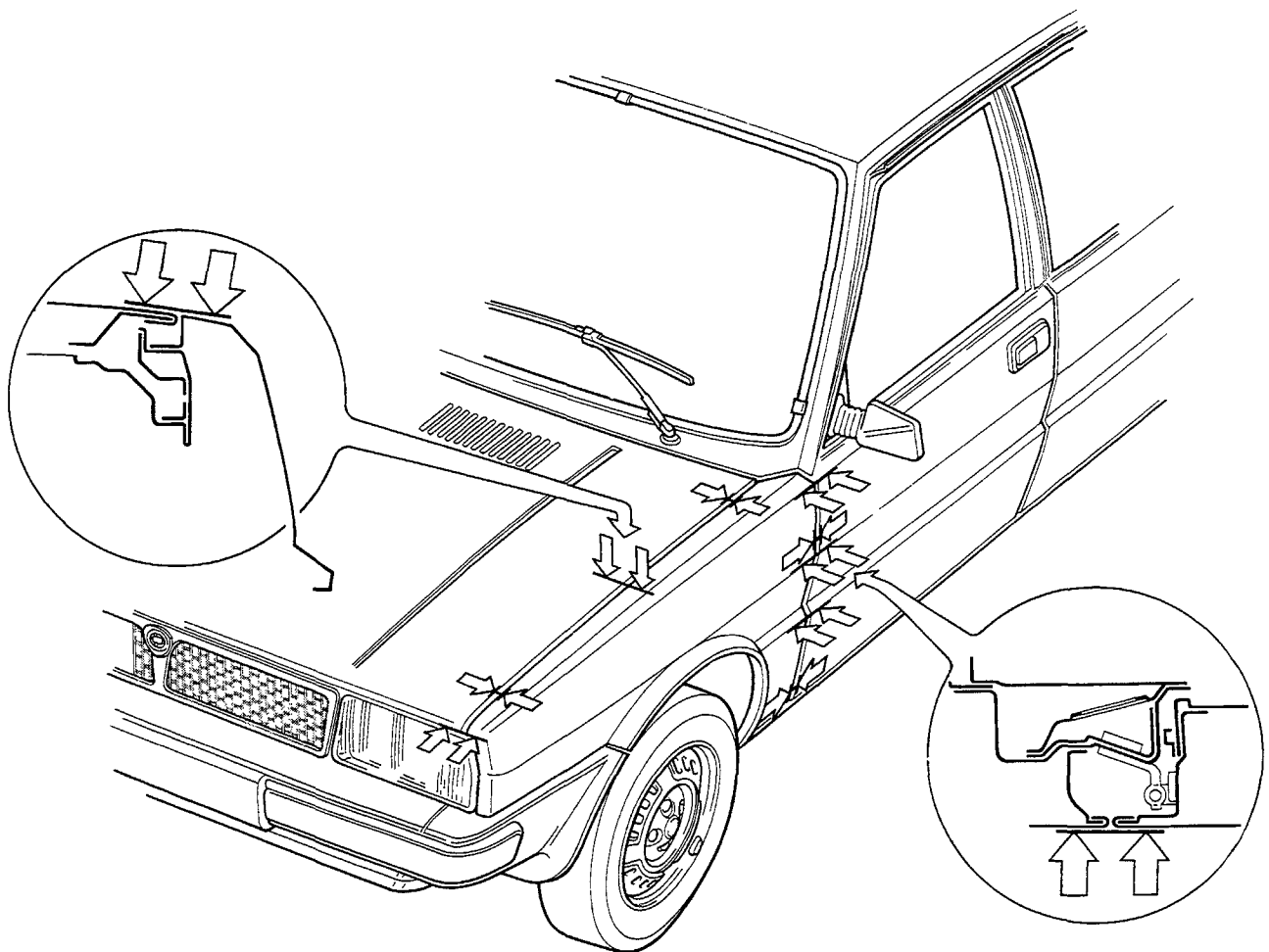

Fit the wing without fully tightening the bolts for securing it to the bodyshell.

Make sure that the door and the bonnet lid open and close properly.

Check that the ribs line up and that all the way round the perimeter of the wing it lies in the same plane as adjacent parts and that the clearance is the same all the way round. If all is well, tighten the bolts securing it to the bodyshell fully.

Seal the joints between the wing and the front section properly.



**70.**

**REPLACING ROOF**

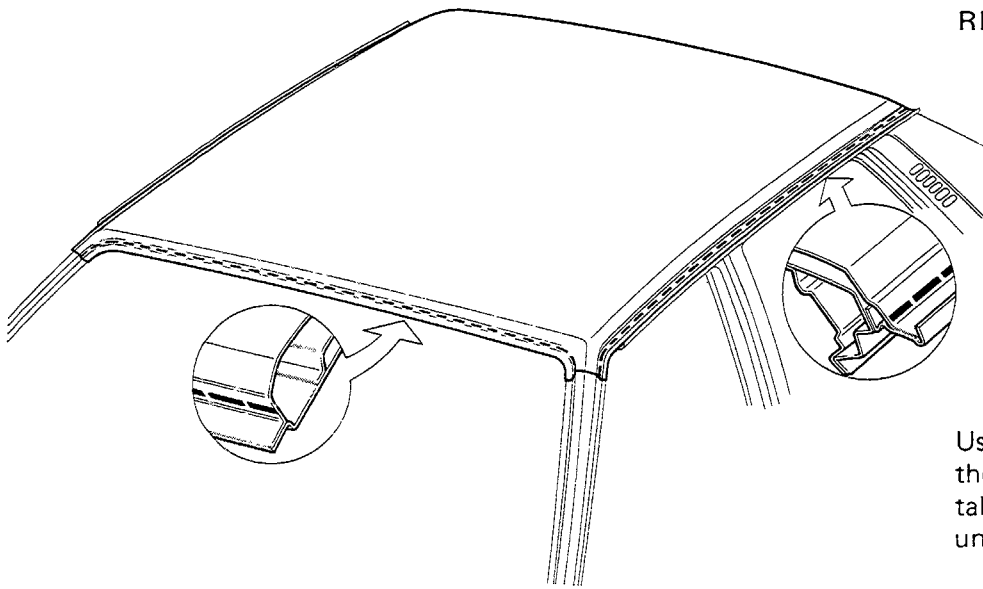

Using a pneumatic hacksaw, cut the roof along the broken lines, taking care not to cut into the underlying framework.

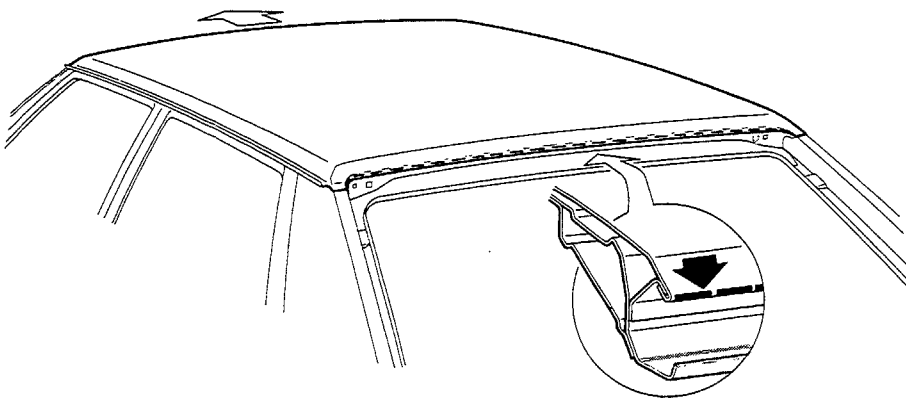

Grind along the rear edge of the roof until it becomes detached from the part of it which was folded over, taking care not to damage the underlying curved rib.

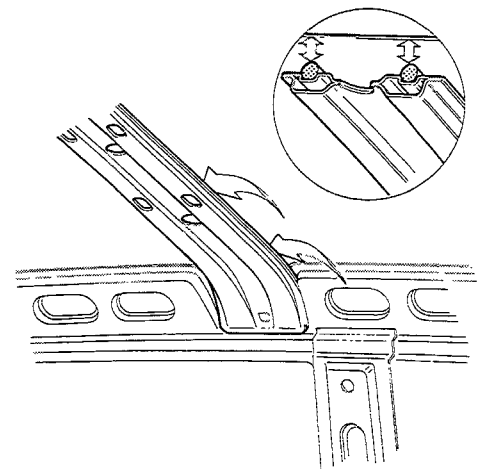
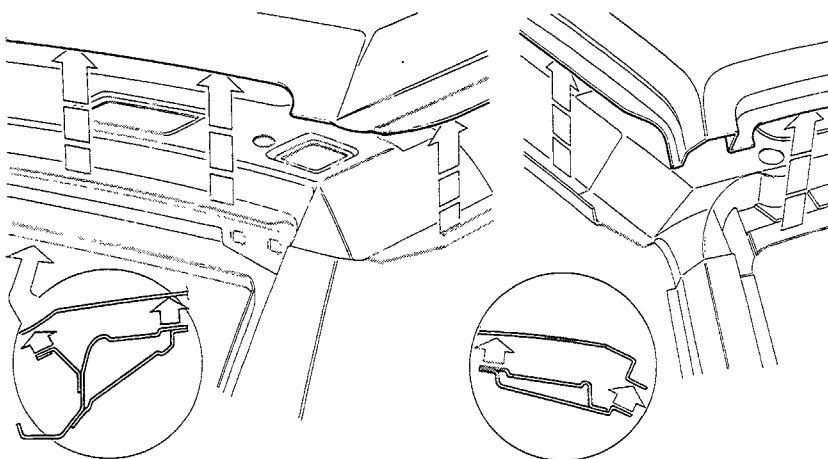

Near where the roof is welded to the pillars (on the parts which have not been replaced) spread a mixture consisting of crumbled asbestos worked into a dough with water and, using an oxyacetylene torch and a wire brush, unweld the joints.

Remove the roof from the central curved rib by inserting a chisel between the vibration-deadening material and the roof

Weaken the lines of continuous welding from A to B along the drip channel, using a disk grinding wheel.

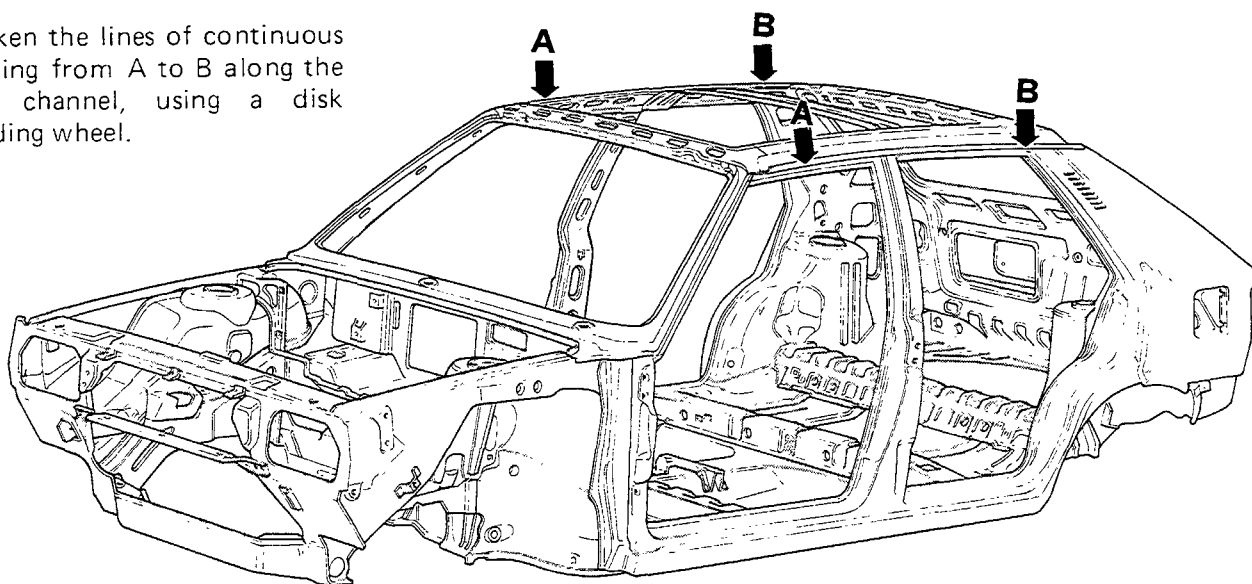

Detach the remaining joining points from the scraps of sheet metal using a suitable milling cutter. Remove the scraps of sheet metal using tongs.

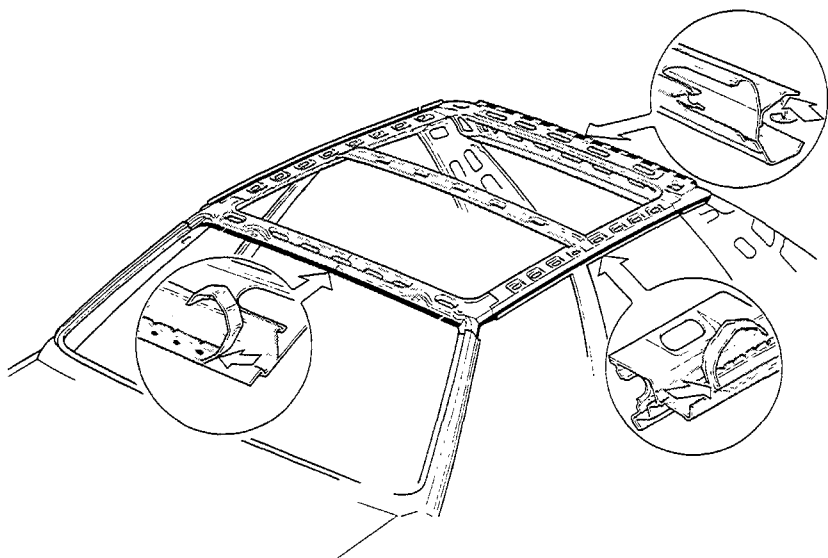

Using a torch, burn off every trace of oxide, sealant or paint from the welding edges, then brush them.

Straighten and grind the fins shown by the white arrows and protect them with a zinc-based anti-rust agent.

Spread structural adhesive on the fin shown by the black arrow.

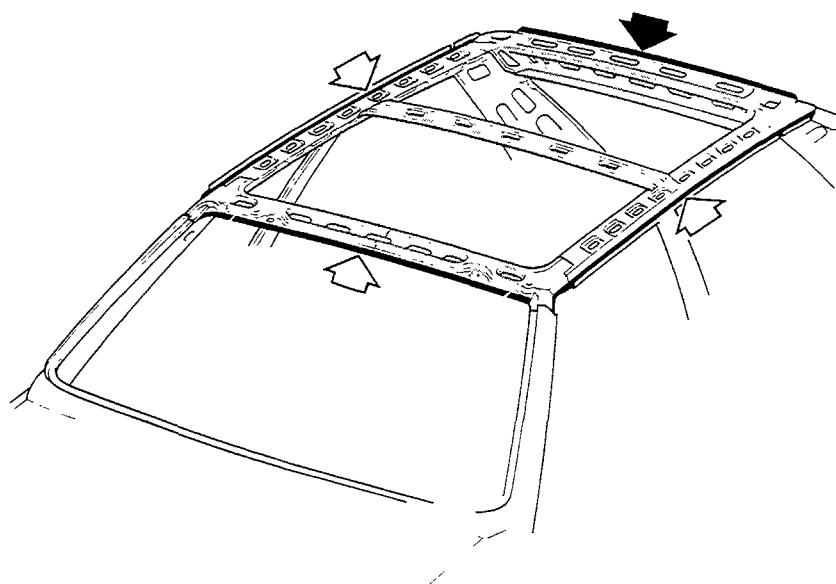

**70.**

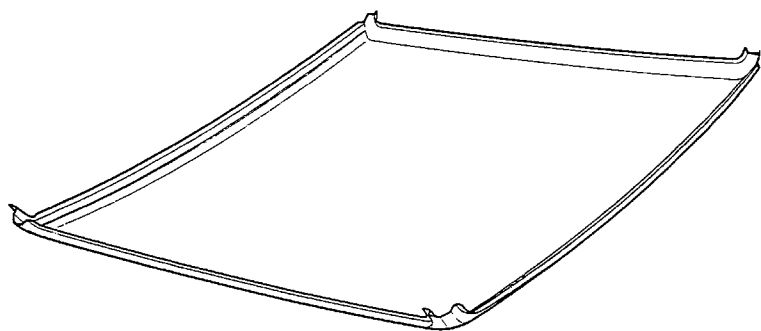

Grind the welding edges of the replacement part and protect them with a zinc-based anti-rust agent.

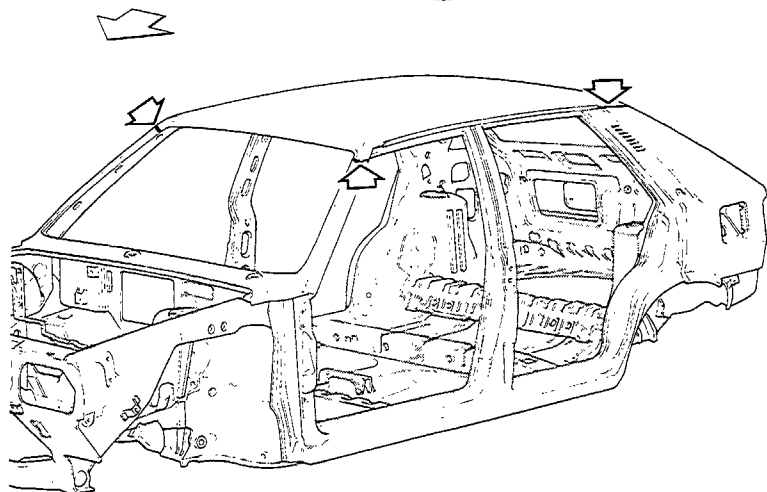

Fit the replacement part in position, fix it with self-locking pliers and check that it joins up with the pillars correctly.

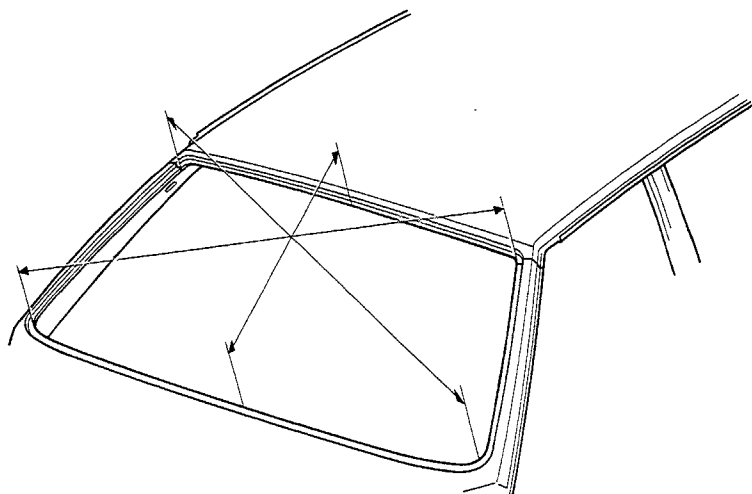

Check the depth of the space for housing the windscreen and also that the diagonal measurements across this space are the same.

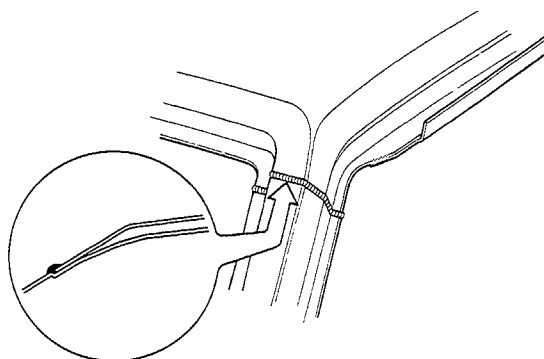
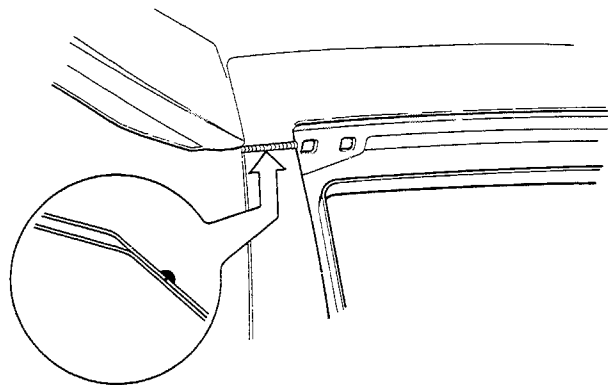

Initially perforate the roof-pillar junctions, then complete the welds using an inert gas electrode.

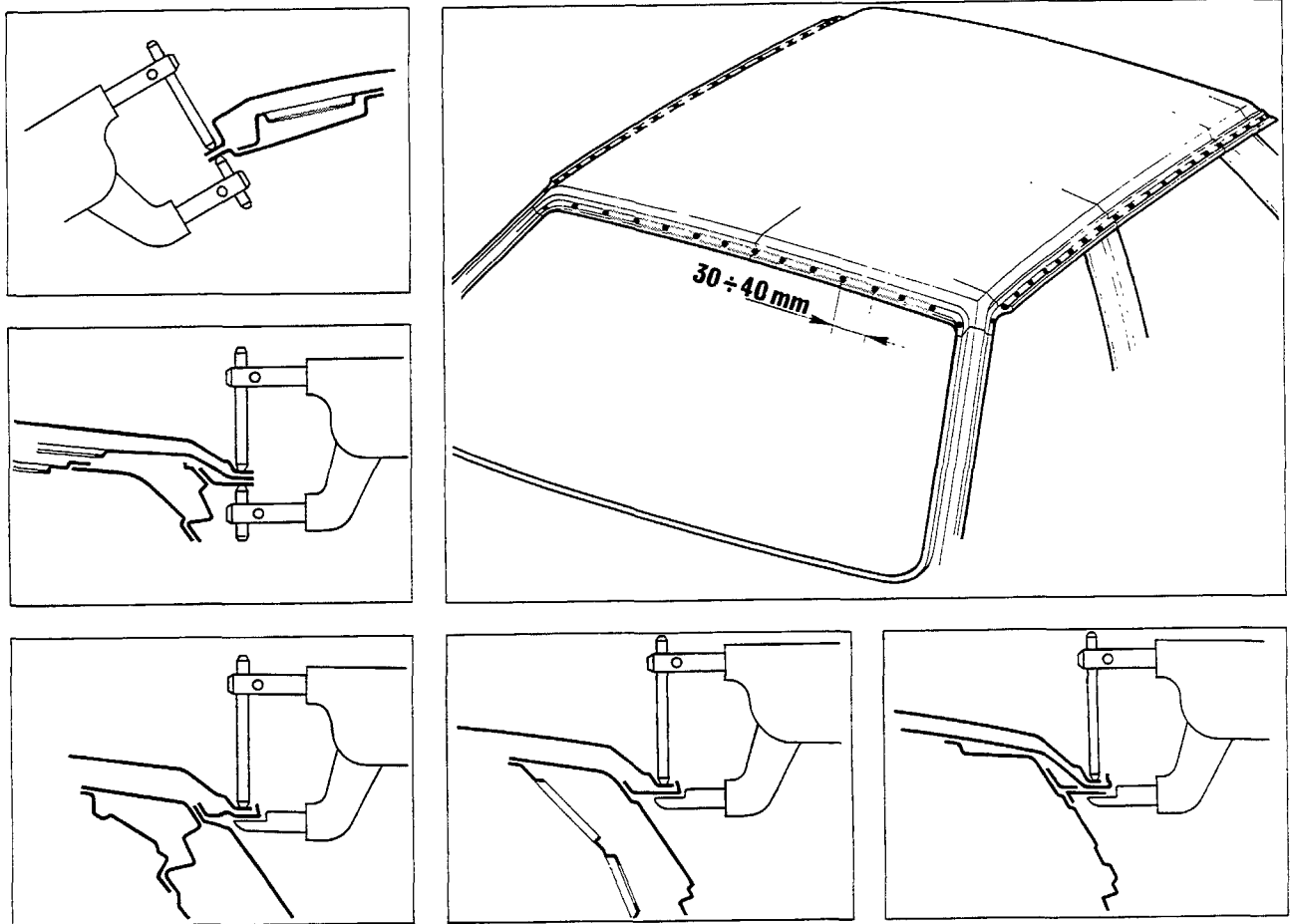

Continue welding the roof in the areas shown using an electric spot welder.

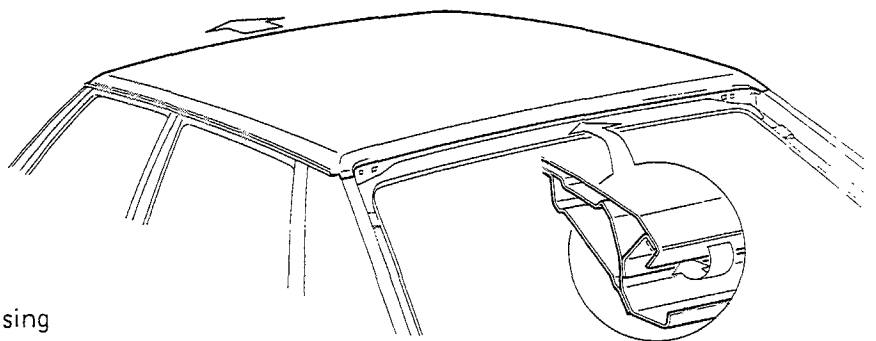

Fold the rear edge of the roof over using a hammer and steel block

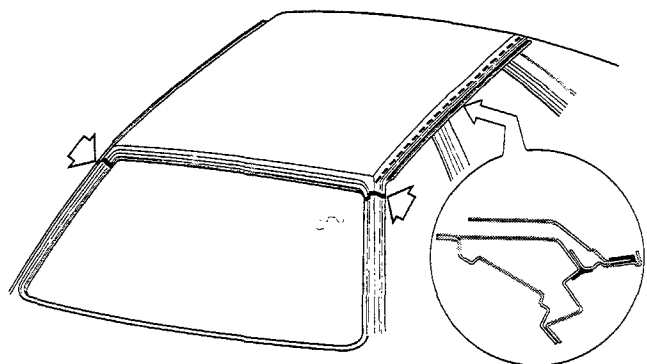

Complete the operation by smearing hot setting sealant for external use in the areas shown.

**70.**

**REPLACING UPPER WINDSCREEN CROSSMEMBER (FRONT CURVED RIB)**

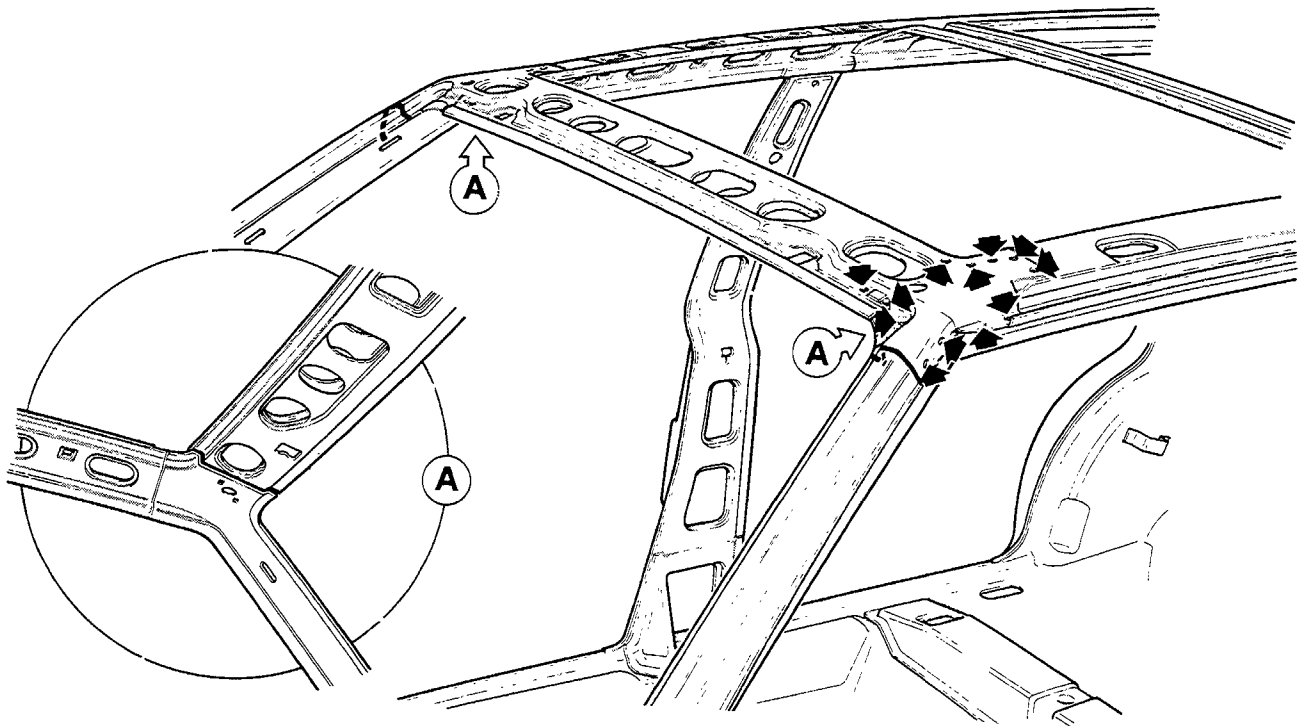

Using a pneumatic hacksaw cut the crossmember in the areas marked A.  
Detach the welding points marked by the black arrows using a suitable milling cutter.

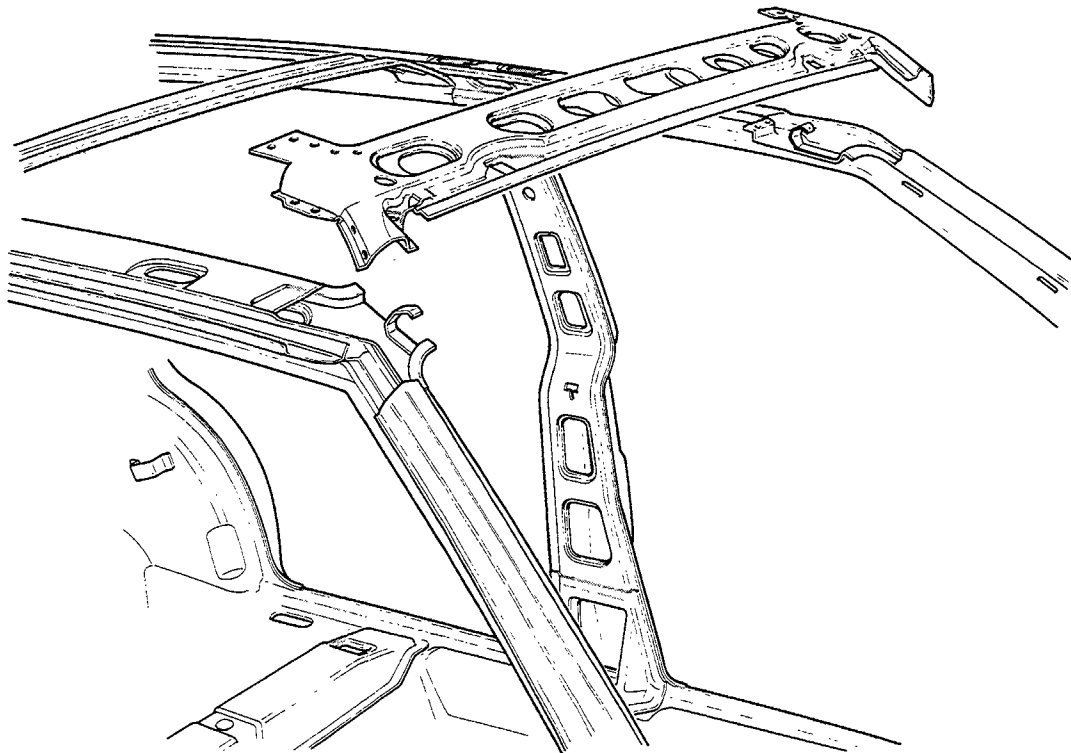

Remove the scraps of sheet metal and straighten and grind the welding edges.

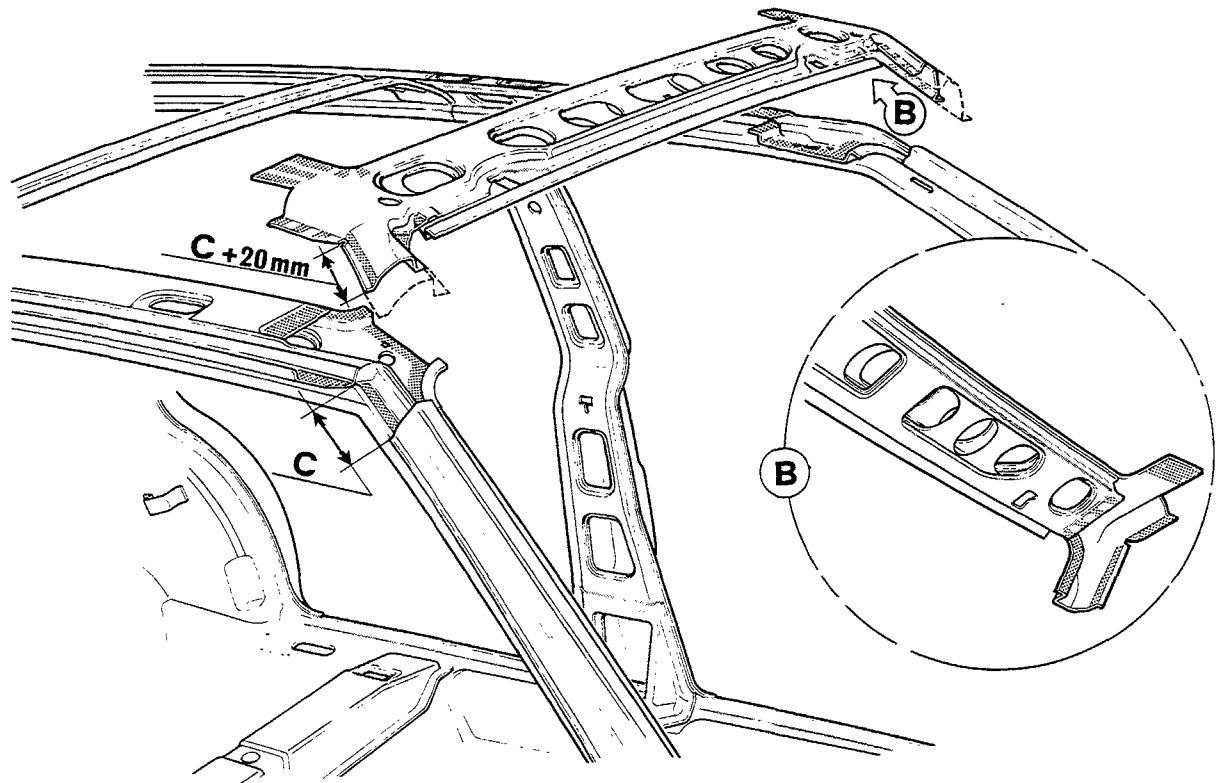

Measure dimension C and mark off the same dimension + 20mm on the replacement part and cut it to this measurement. Grind the welding areas on the replacement part and protect the shaded areas B with a zinc-based anti-rust agent. Fit the replacement part in position, laying it over the non-replaced part, fix it with self-locking pliers and cut both parts together (on the overlap). Check, using a test gauge, the depth of the housing for the windscreen and also check that the diagonal measurements of this housing are the same.

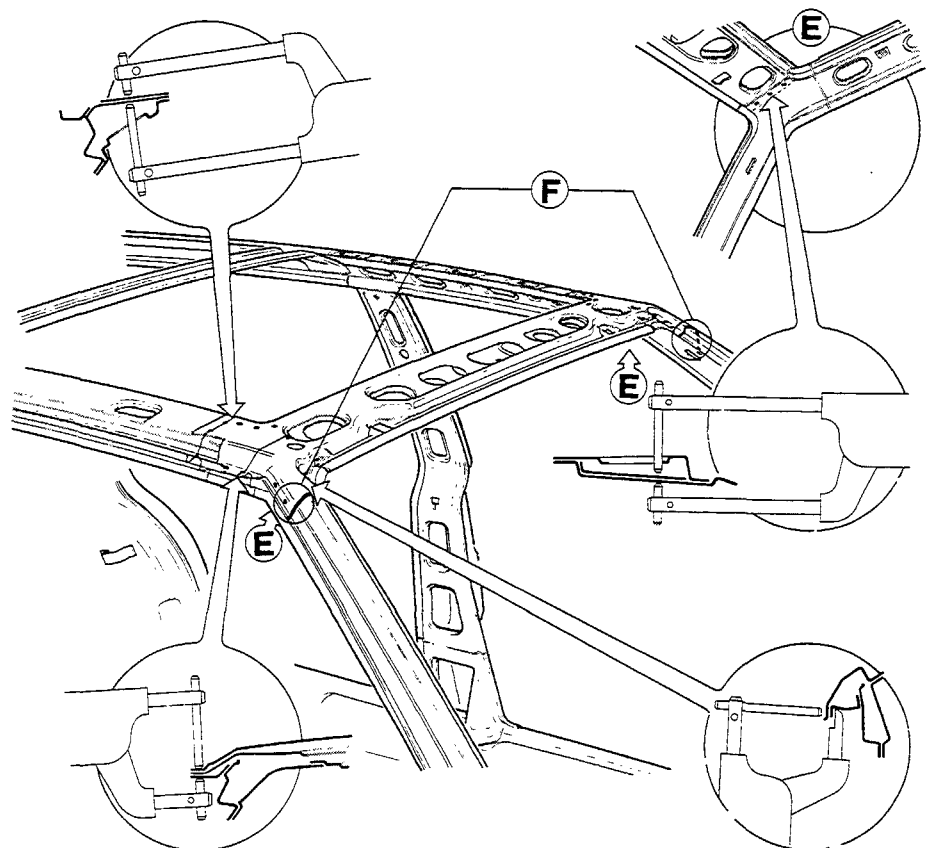

Weld the upper windscreen crossmember to the interior framework using a spot welder. Then weld along the lines marked F using an inert gas electrode.

**70.**

**REPLACING WINDSCREEN SURROUND**

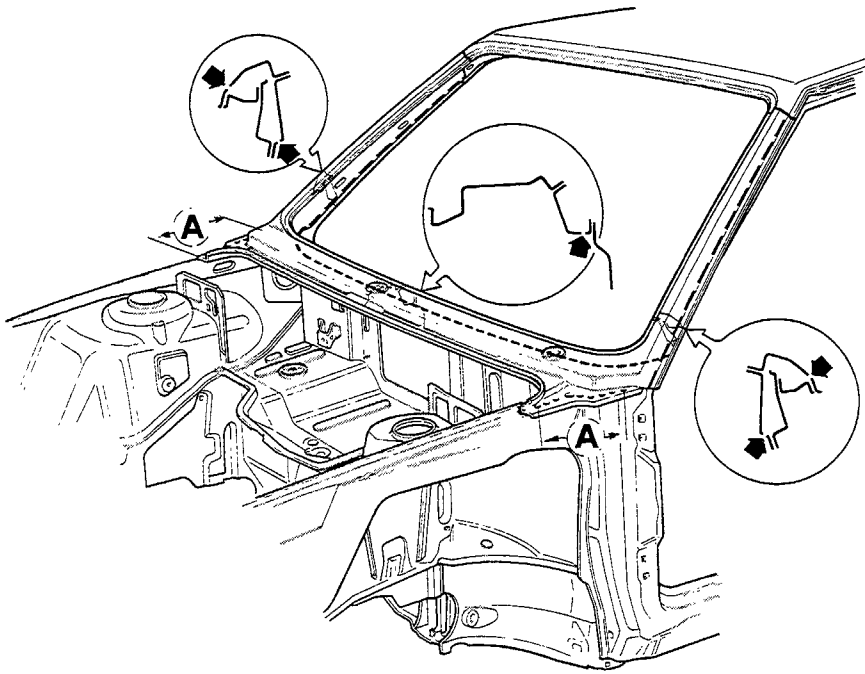

Cut the windscreen surround along the broken lines using a pneumatic hacksaw.

Detach the welding points in the sections marked A using a milling cutter, then remove the damaged part.

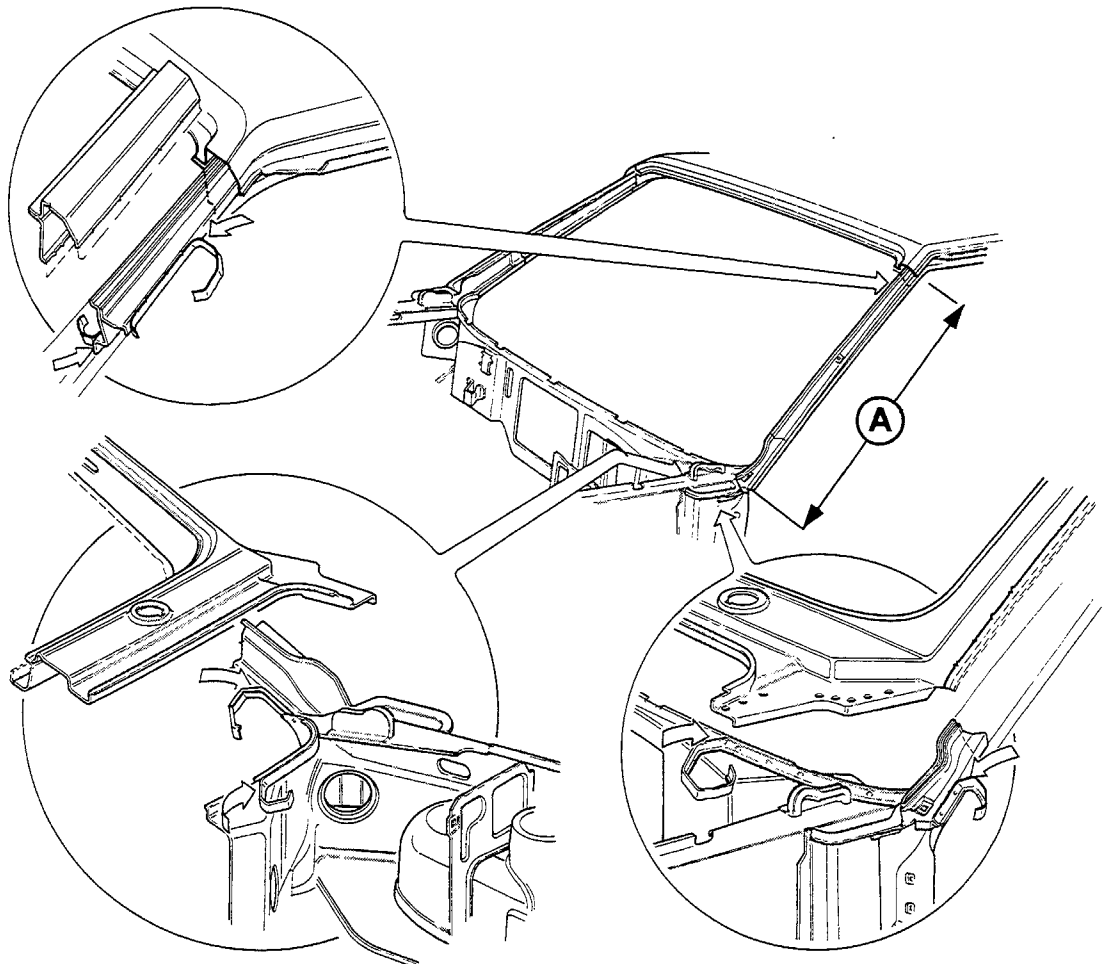

Detach the joining points in the scraps of sheet metal using a suitable milling cutter. Remove the scraps of sheet metal using tongs. Clean up the welding edges and measure dimension A.

Mark off dimension A + 20mm on the replacement part and cut it to this measurement; grind the welding fins on the replacement part and protect all the welding areas, as shown, using a zinc-based anti-rust agent. Fit the replacement part in position laying it over the non-replaced parts, fix it with self-locking pliers and cut both parts together (on the overlap). Check the depth of the housing for the windscreen and also check that the diagonal measurements of this housing are the same.

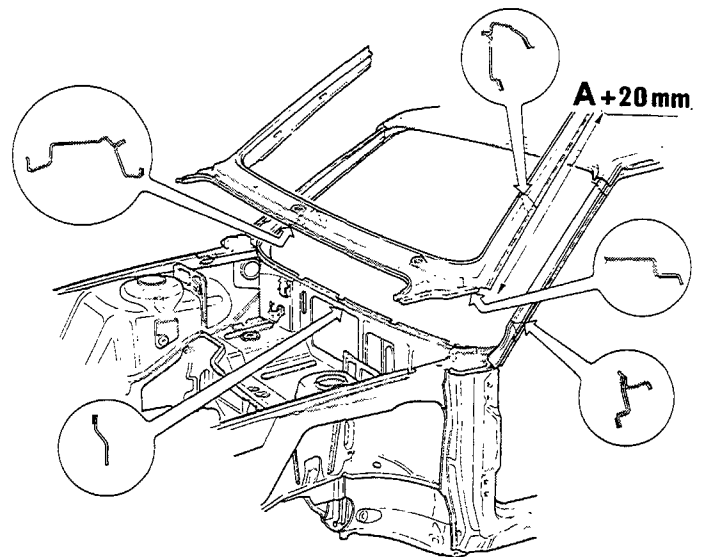

Spot weld the windscreen surround to the interior framework.

Complete the job of fixing the windscreen surround by welding it using the inert gas electrode method at the points shown by the letter B.

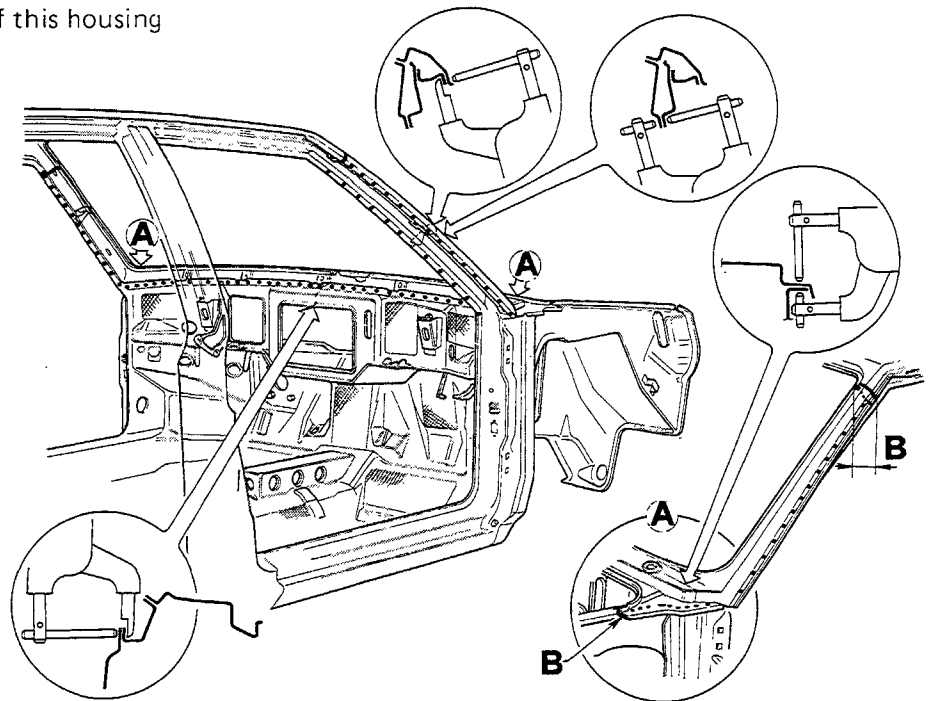

Re-seal the joints using hot thermosetting plastic sealant in the sections shown by the arrows.

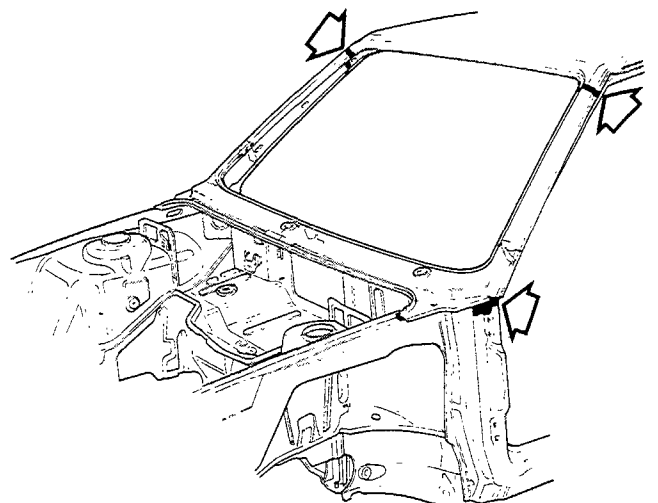



**70.**

**REPLACING COMPLETE DOOR SILL**

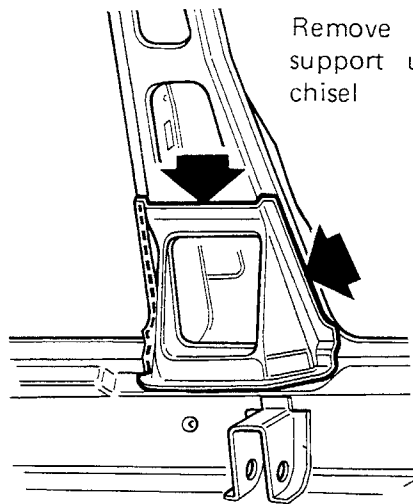

Remove the interior pillar support using a pneumatic chisel

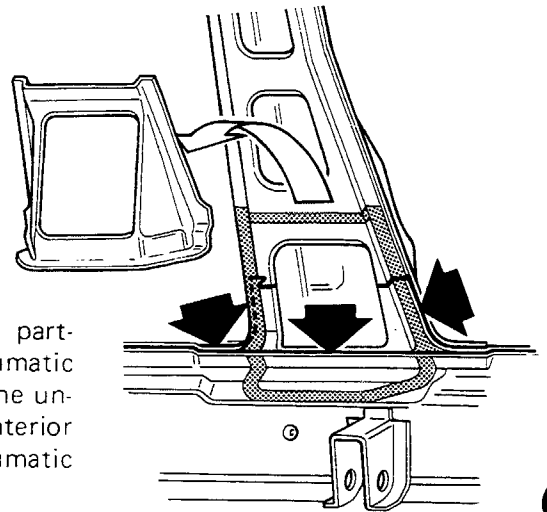

Cut the interior pillar partway up using a pneumatic hacksaw and remove the underlying part of the interior pillar using a pneumatic chisel.

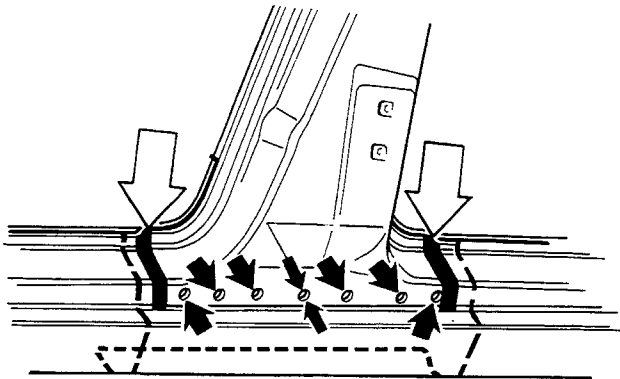

Using an oxyacetylene torch, unweld the sections of welding marked with white arrows. Detach the welding points shown by the black arrows and cut the section of door sill along the broken lines.

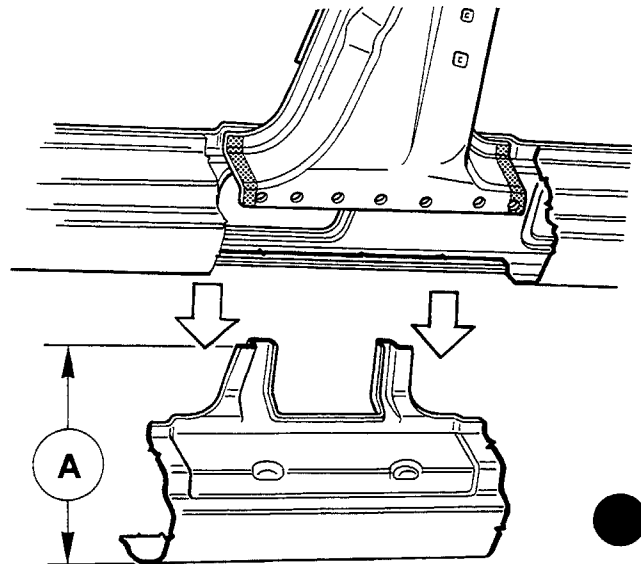

Release the section of door sill which has just been unwelded from the pillar and remove it.

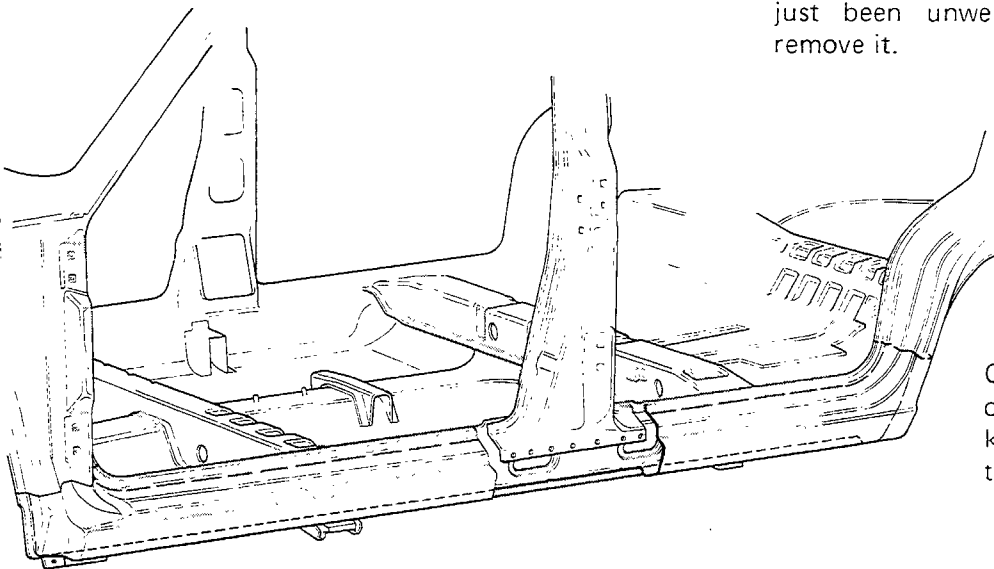

Cut the remaining section of door sill along the broken lines using a pneumatic hacksaw or chisel.

Detach the joining points of the scraps of sheet metal using a suitable milling cutter. Remove the scraps of sheet metal using tongs. Burn off every trace of oxide, paint or protective from the welding edges, then brush them. Straighten the welding edges using a hammer and shaped block.

Take the measurements of the parts which are to be replaced, and mark off the same measurements + 30mm on the replacement part and cut it to these measurements. Cut off the upper limit of the central pillar, shown by the arrow laying part A, previously removed on top. Grind the welding edges on the bodyshell and on the replacement part using a disk grinding wheel.

Apply zinc-based anti-rust protection to the welding edges shown by the shading. Fit the complete door sill in position, fixing it with self-locking pliers, and cut the parts together (on the overlap) and remove the scraps. Drill 8 holes in the replacement part at the points shown by the white arrows corresponding to the position of the fins on the bodyshell (shown by the black arrows) and the front edge of the door sill.

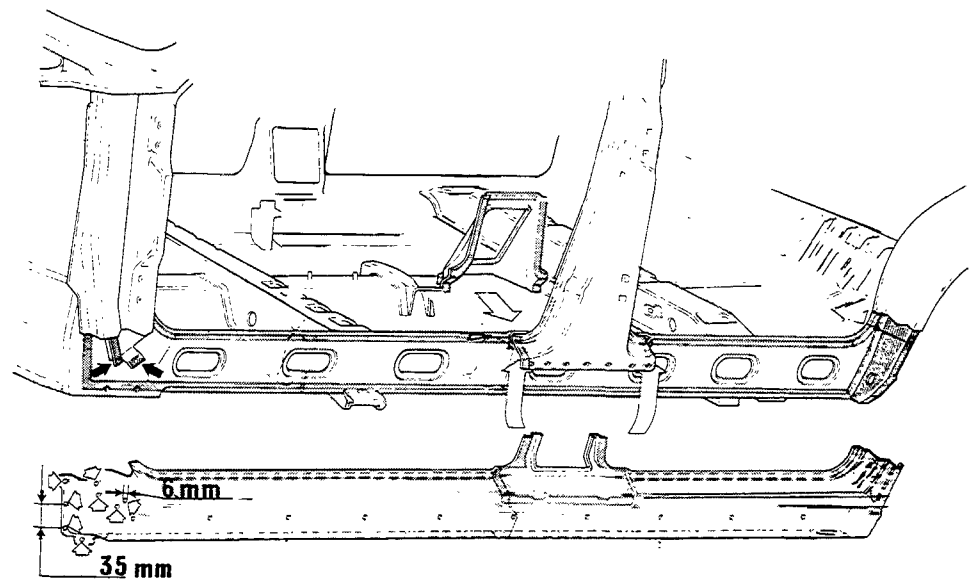
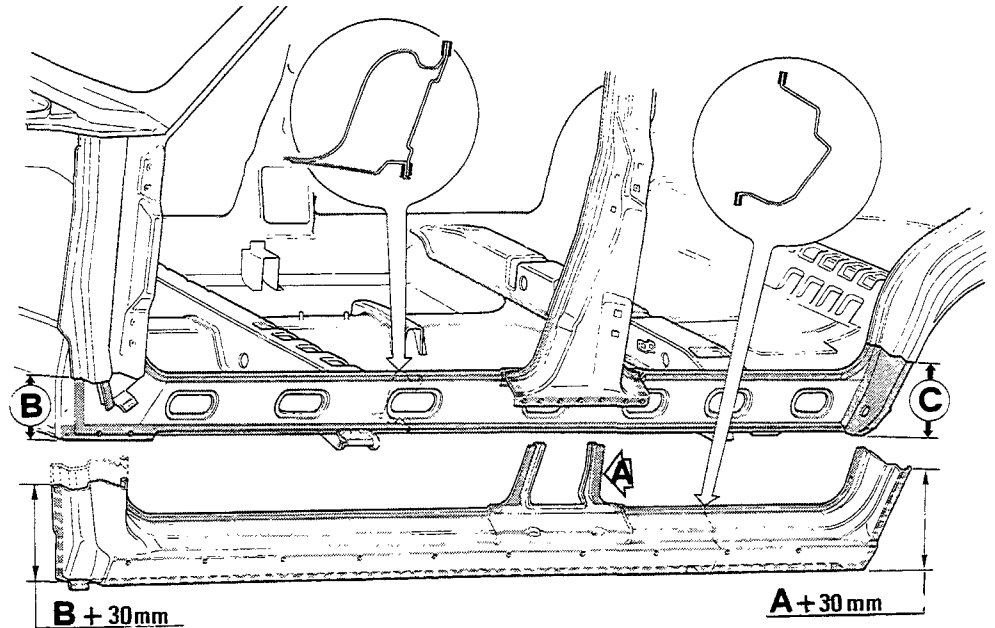
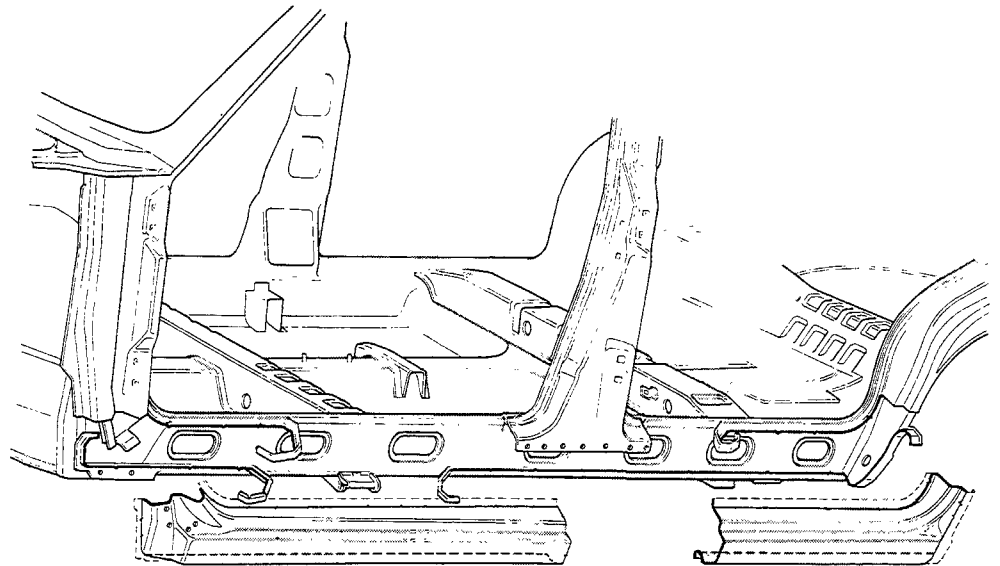

**70.**

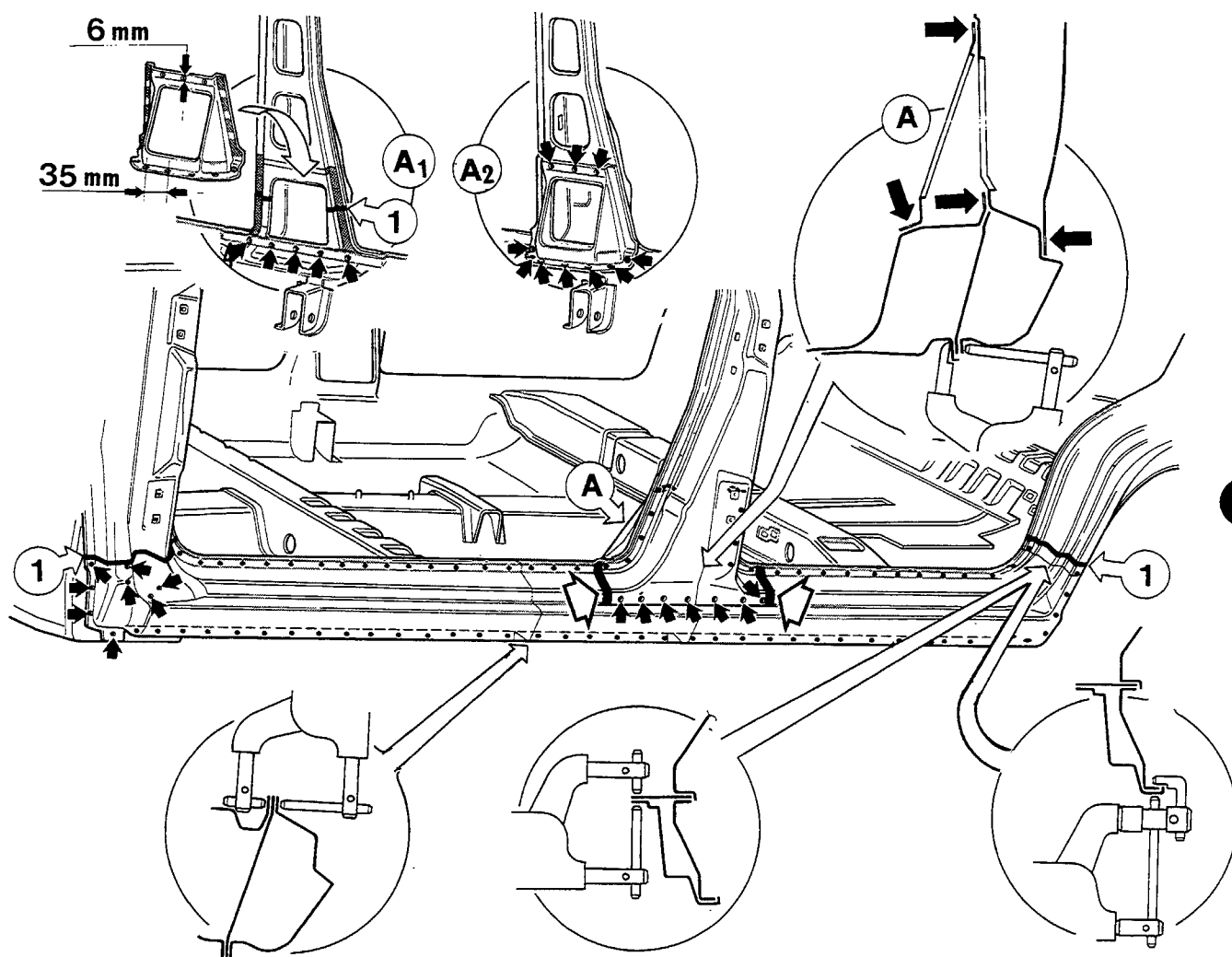

Weld the joints marked (1) by the inert gas electrode method. Weld the interior pillar to the bodyshell using a spot welder. Drill a series of holes in the interior support and in the body shell as shown magnified in detail A<sub>1</sub>. Weld the support to the interior pillar filling the holes which have just been drilled by the inert gas electrode method as shown magnified in detail A<sub>2</sub>. Weld the complete door sill to the body shell and to the fitted interior support using a spot welder. Weld the base of the pillar to the door sill by the inert gas electrode method as shown by the white and black arrows.

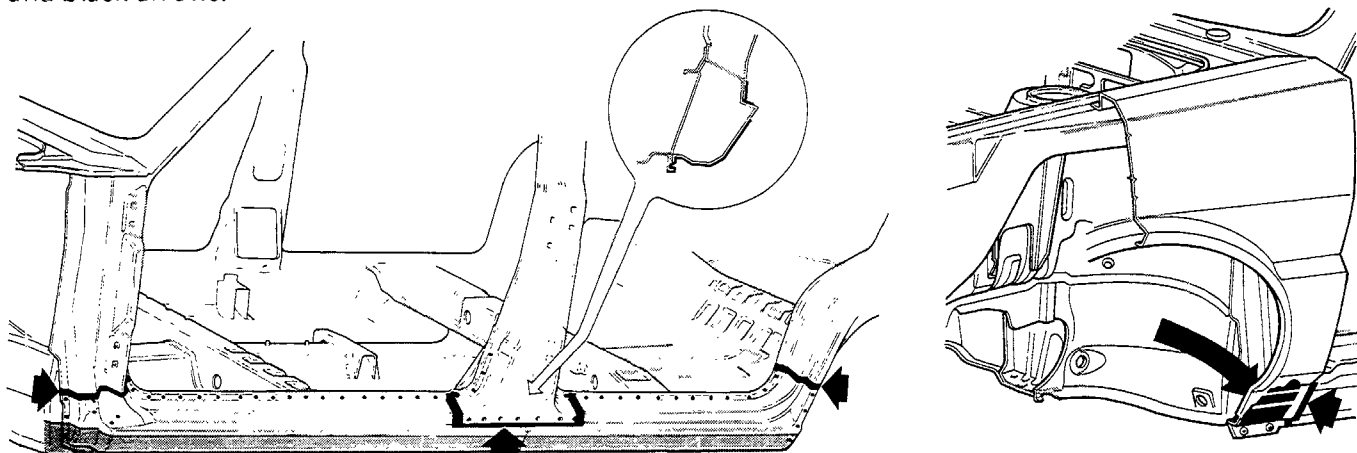

Using a brush, spread hot-setting sealant for external use in the areas indicated by the black arrows. After applying a primer to the shaded areas, spray them with a vinyl protective.

With the wing fitted, renew the hot-setting sealant for external use in the areas shown.

## REPLACING A SECTION OF DOORSILL (METHOD A)

Cut the door sill at the points shown by the broken lines, using a pneumatic hacksaw or chisel.

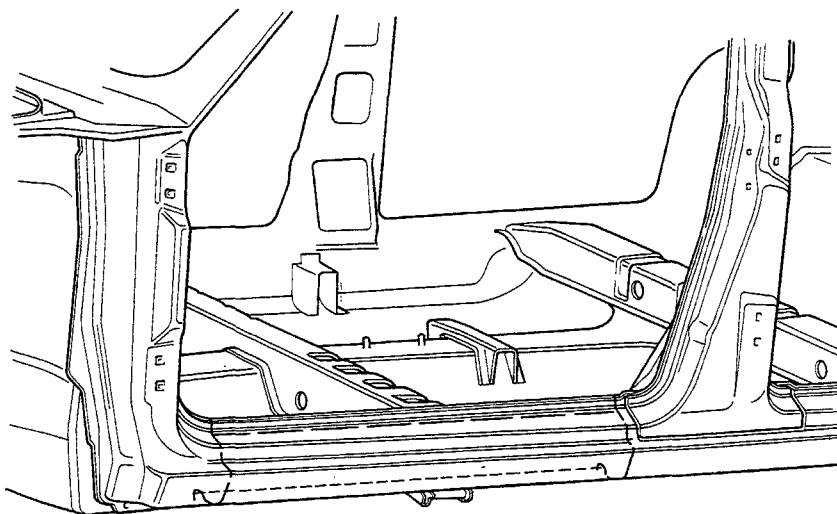

Detach the welding points using a suitable milling cutter.

Remove the scraps of sheet metal using tongs.

Measure the length of door frame needing to be replaced A.

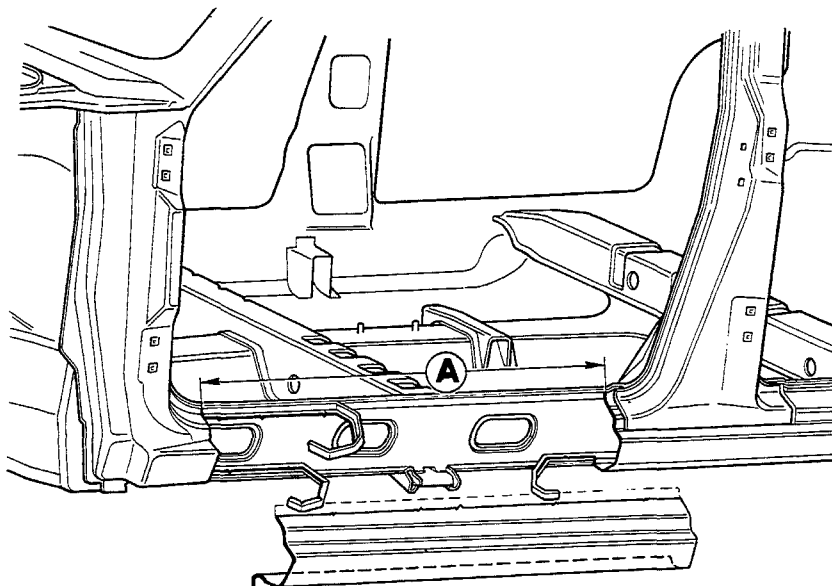

Mark off the same measurement + 20mm on the replacement part and cut it to this measurement.

Straighten the welding edges (shaded areas) and clean them using an oxyacetylene flame.

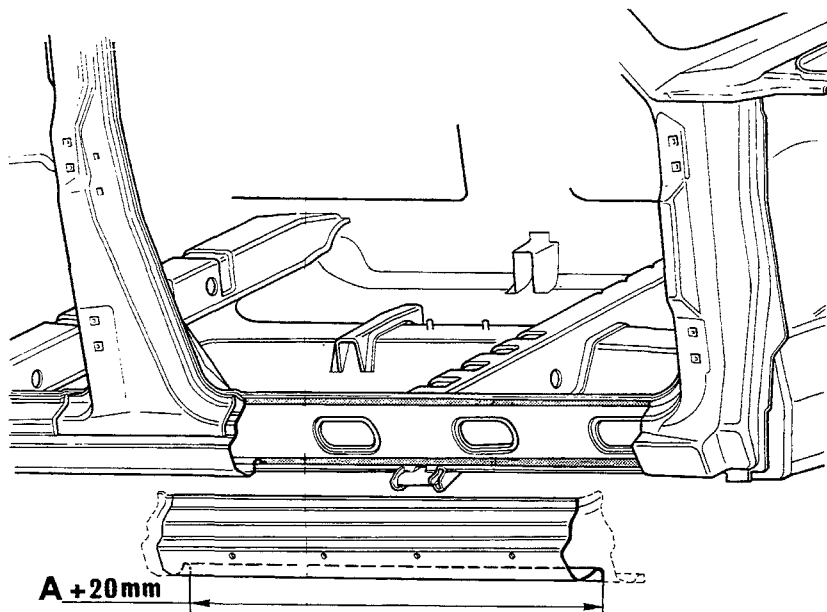

## Bodywork

### Replacing panel sections

#### 70.

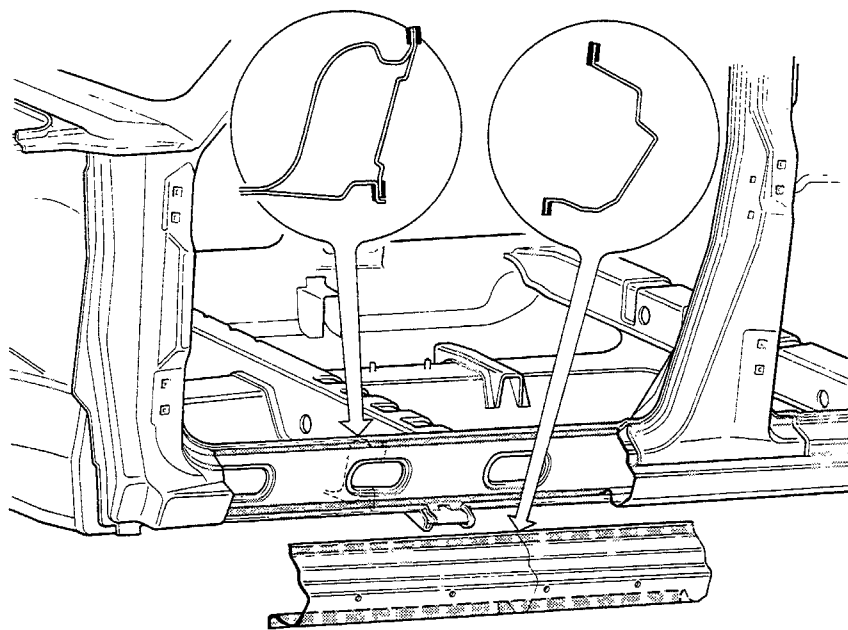

Grind the points on the replacement parts which are to be welded.

Protect the areas shown using a zinc-based anti-rust agent.

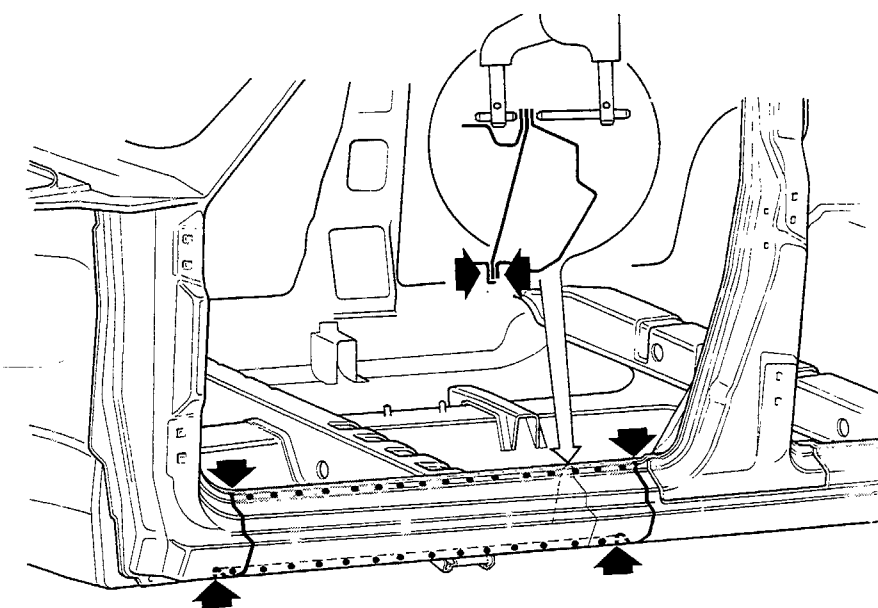

Fit the replacement part in position, fixing it with self-locking pliers, and cut the parts together (on the overlap). Fit the door and check that it is parallel with the longitudinal member and that there is a uniform gap.

Weld the joints shown by the arrows using the inert gas electrode method.

Spot weld the door sill to the bodyshell as shown magnified in the detail.

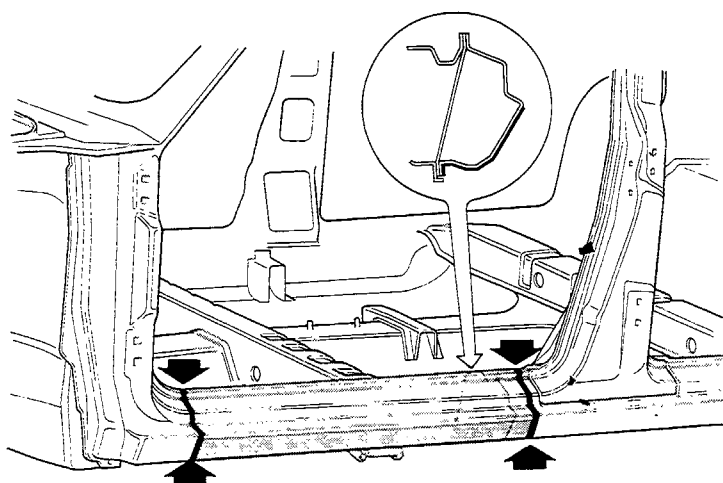

Touch up the side joints as appropriate by grinding.

Smear hot-setting sealant for outside use along the joints shown by the arrows.

Spray a waxy-oil protective into the replaced box section and - after applying a coat of primer - renew the vinyl-based protective in the shaded area.

REPLACING A SECTION OF  
DOORSILL (METHOD B)

Cut the doorsill at the points shown by the broken lines, using a pneumatic hacksaw or chisel.

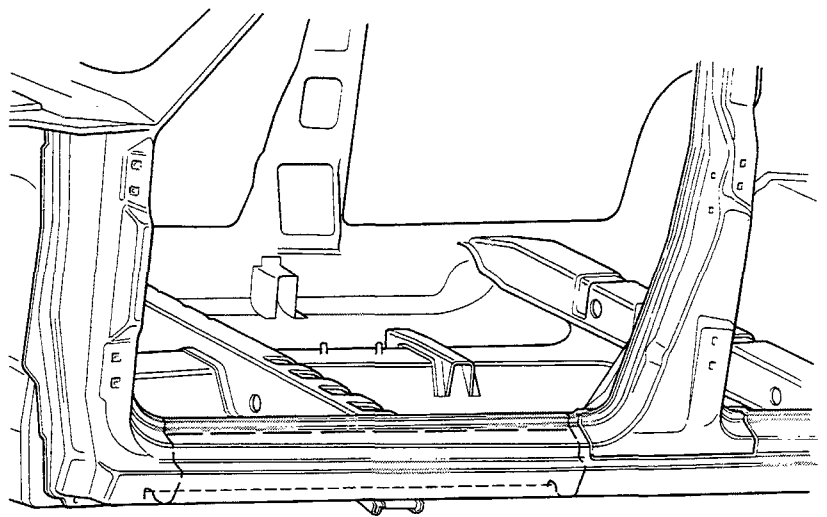

Detach the welding points using a suitable milling cutter. Remove the scraps of sheet metal using tongs. Measure the length of door sill which needs to be replaced A.

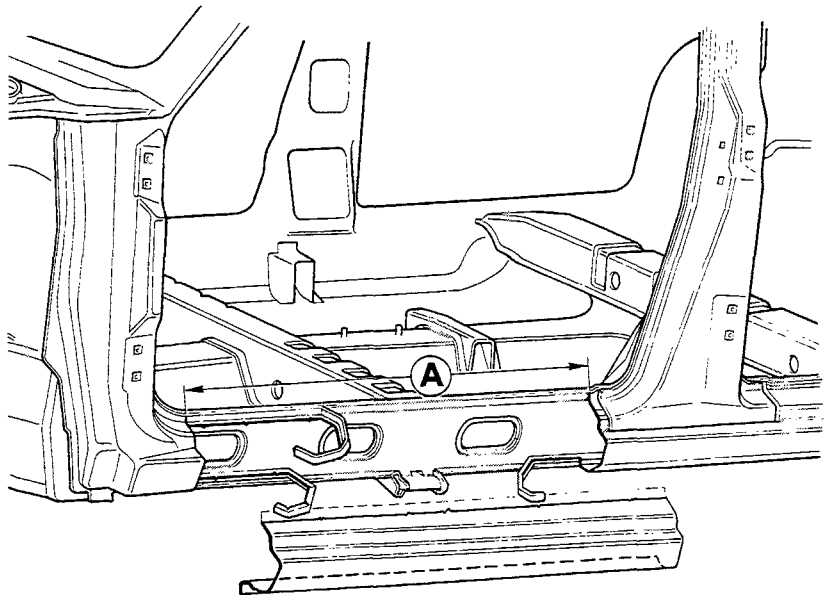

Using plate-shears, cut and lower the joining surfaces along the 2 cuts marked B, as shown magnified in details B<sub>1</sub> and B<sub>2</sub>.

Straighten the welding edges, grind them externally and internally and apply a zinc-based anti-rust agent (shaded areas)

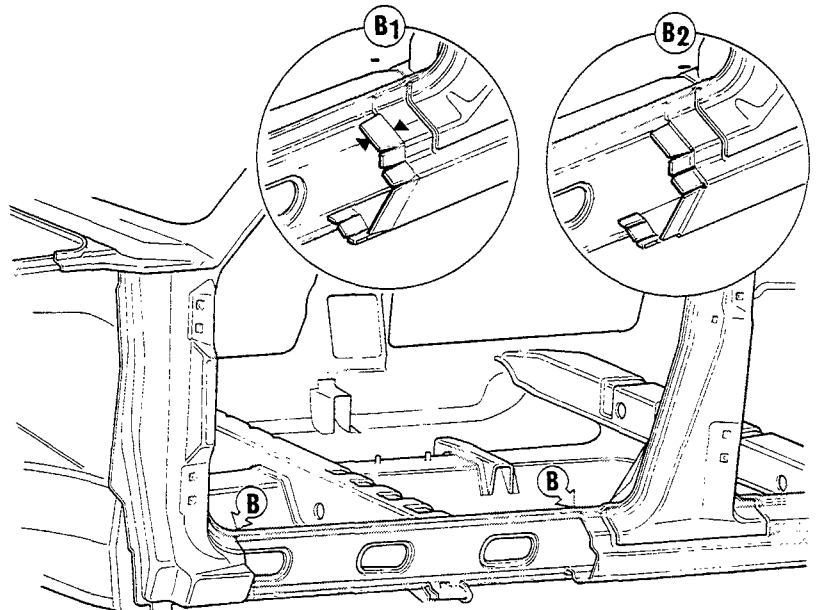

**70.**

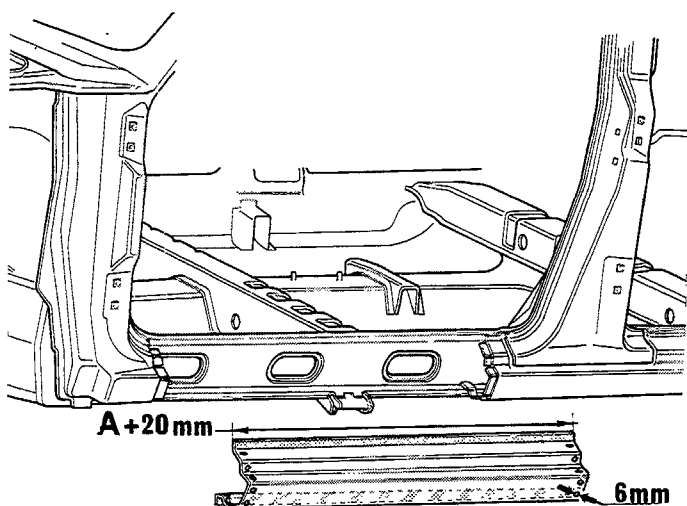

Mark off length A + 20mm on the replacement part and cut it to this measurement.

Drill a series of holes, each with its centre between 6 and 7mm from the edge.

Grind the welding areas shown and protect them with a zinc-based anti-rust agent.

Position the replacement part, fixing it with self-locking pliers.

Fit the door and check that it is parallel with the longitudinal member and that there is a uniform gap.

Weld the replacement part on the overlap filling the holes (white arrows) using the inert gas method.

Spot weld the door sill to the bodyshell as shown magnified in the detail.

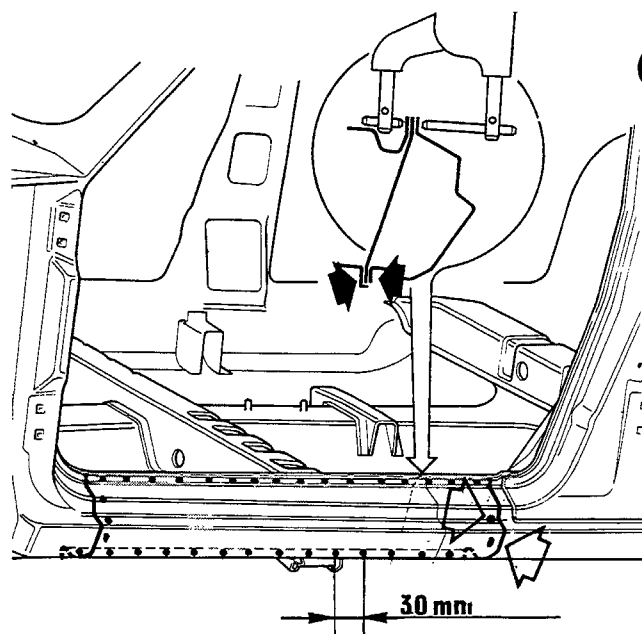

Apply sealing compound to the joints shown, remove any surplus and finish off the surfaces with a file.

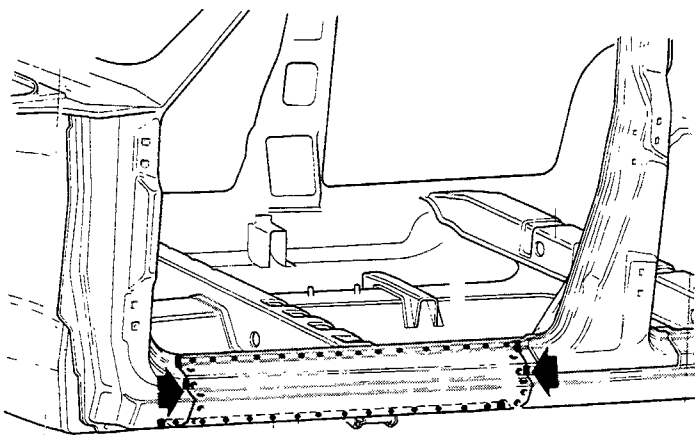

Smear hot-setting sealant for outside use along the joints shown by the arrows.

Spray a waxy-oil protective into the replaced box section and - after applying a coat of primer - renew the vinyl-based protective over the shaded area.

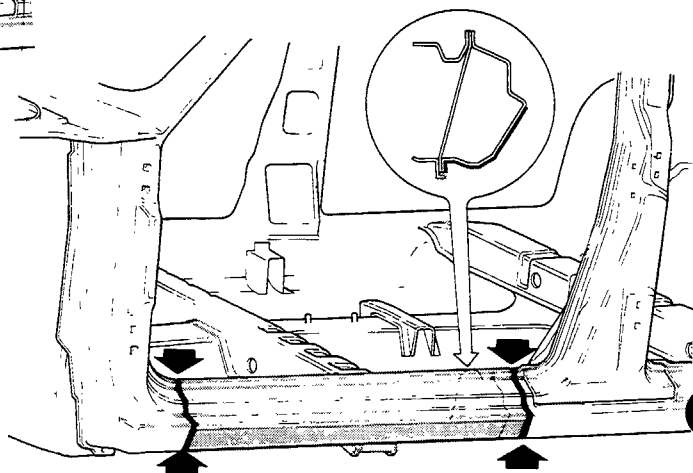

REPLACING PART OF CENTRAL PILLAR (METHOD A)

Cut the outer section of the pillar at the distance from the top shown in the illustration using a pneumatic hacksaw.

Detach the welding points by milling, in the areas shown.

Complete the job of removing the pillar by unwelding or grinding the sections of brazing shown by the arrows.

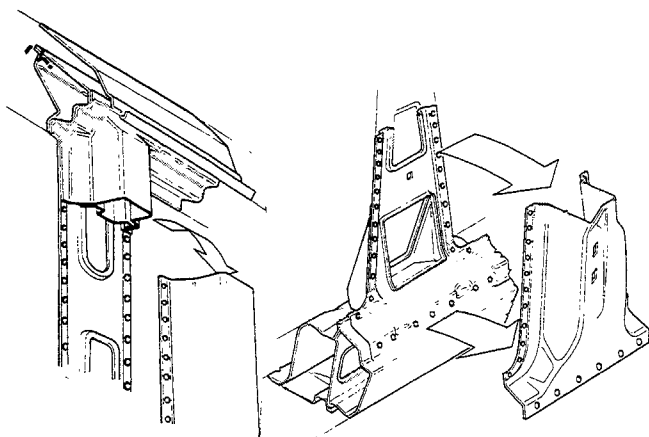
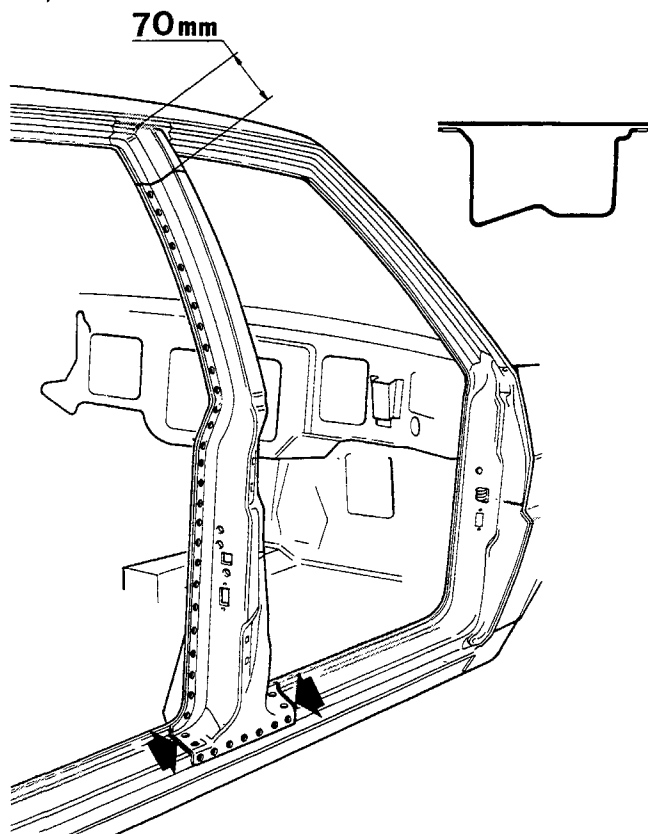

Get rid of every trace of paint from the welding edges using an oxyacetylene torch and wire brush.

Straighten the welding edges using a pneumatic hammer and shaped steel block. Remove the welding points using a disk grinding wheel.

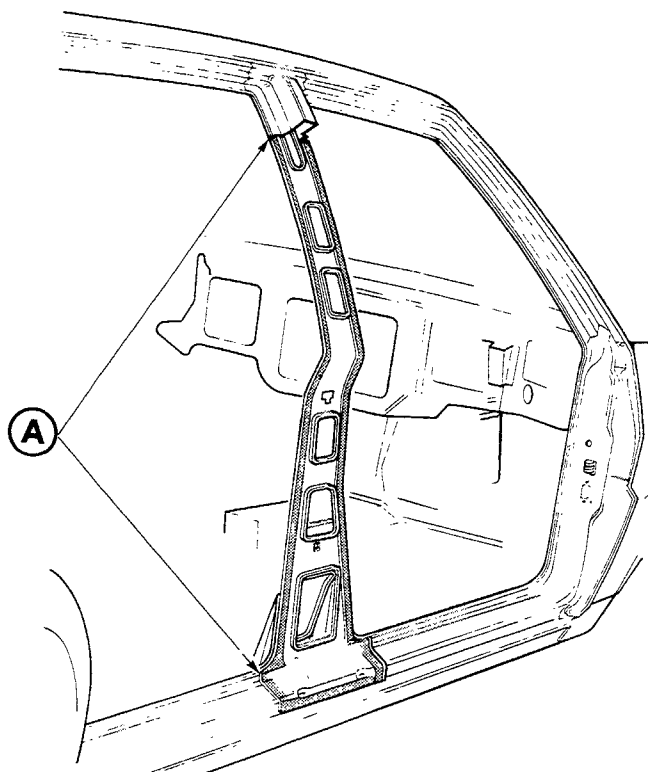

Measure distance A; apply a protective coat of zinc-based paint to the (shaded) areas which are to be welded.



**70.**

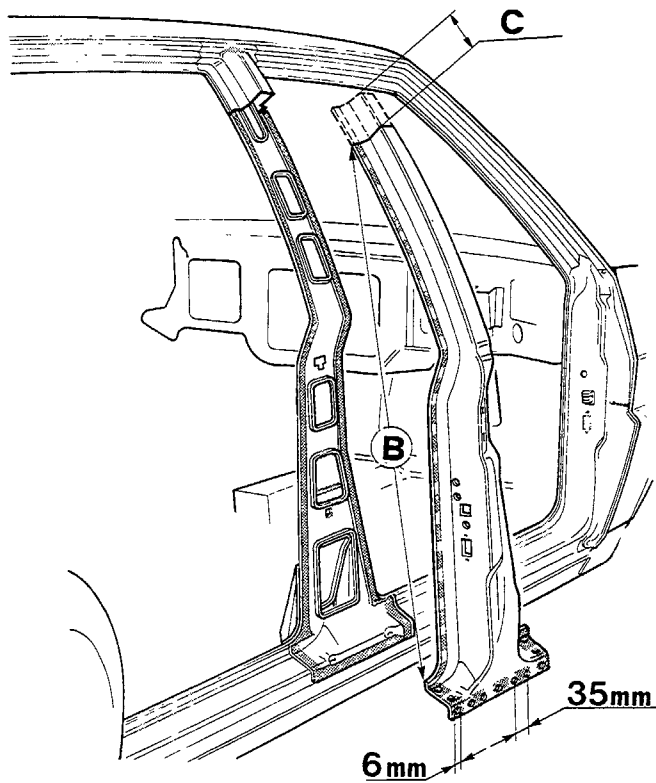

Mark off distance  $B = (A + 20\text{mm})$  on the replacement part and remove part C which is not going to be replaced.

Drill a series of holes as shown and grind and protect the welding areas with a zinc-based anti-rust agent.

Fit the replacement part in position, laying it over the non-replaced part; fix it with self-locking pliers and cut the overlapping ends together. Then remove the scraps.

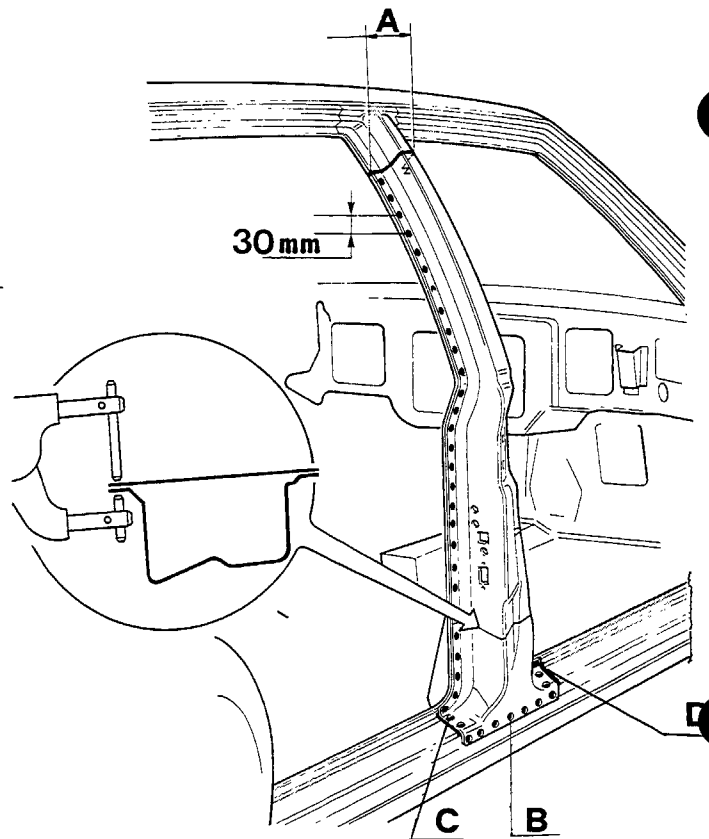

Check the width of the door spaces.  
Weld joint A and joint B by the inert gas electrode method.  
Spot weld the outer section to the inner pillar.  
Brazed along sections C - D.

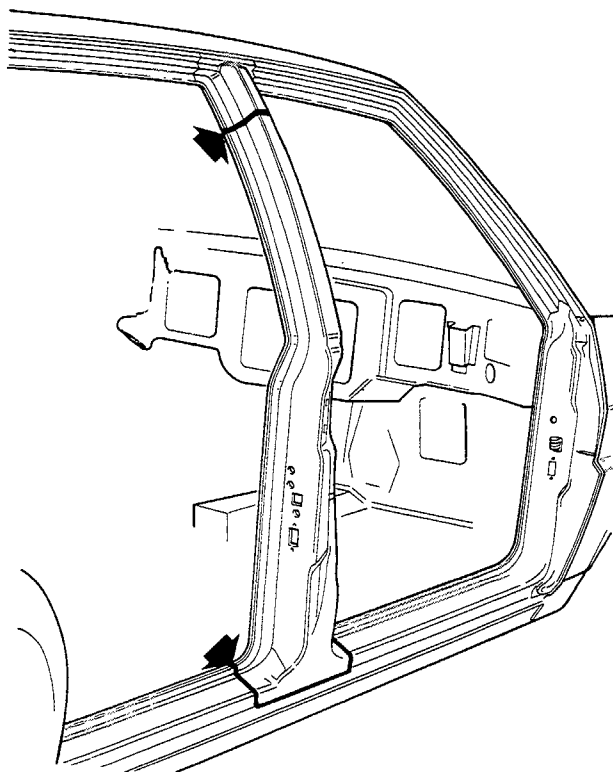

Finish off all the welds carried out using the inert gas electrode method by grinding. If necessary, make the joints on the pillar water-tight and finish by filing.

Complete the operation by renewing the hot-setting sealant in the areas shown by the arrows.

## REPLACING PART OF CENTRAL PILLAR (METHOD B)

Cut the outer section of the pillar at the distance from the top shown in the illustration using a pneumatic hacksaw.

Cut with a pneumatic chisel, following the lines marked by the arrows (1).

Complete the job of removing the pillar by grinding or unwelding with an (oxyacetylene) torch the sections of brazing in the area marked (2).

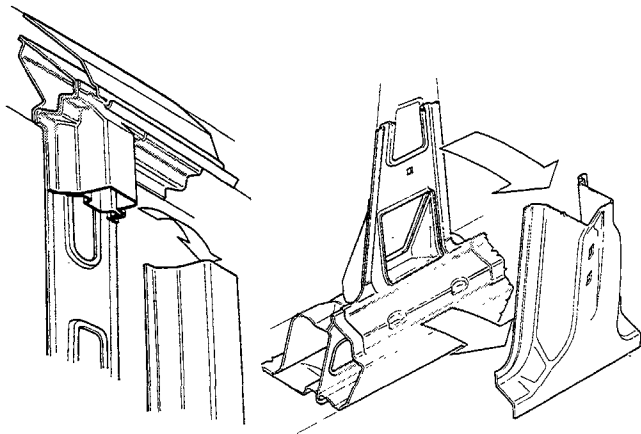
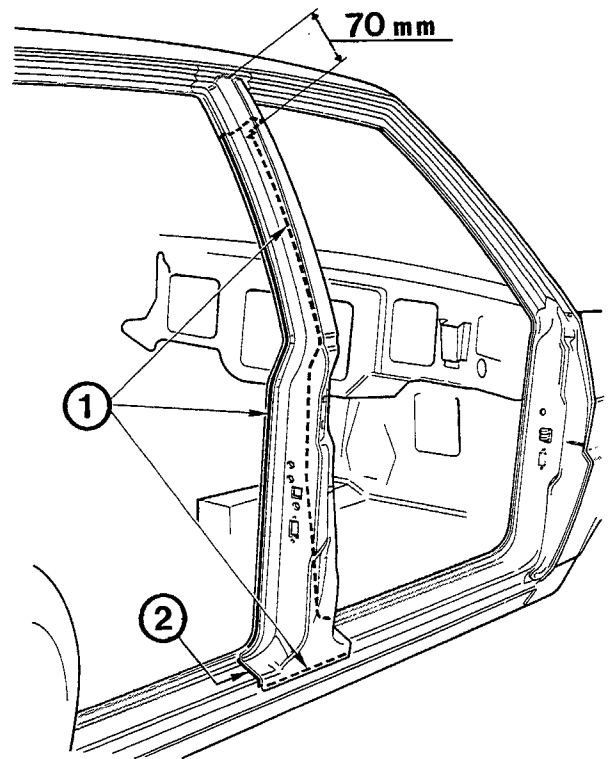

Remove the scraps of sheet metal using tongs. Get rid of every trace of paint from the welding edges using an oxyacetylene torch and wire brush.

Straighten the welding edges using a pneumatic hammer and shaped steel block.

Then finish them by grinding.

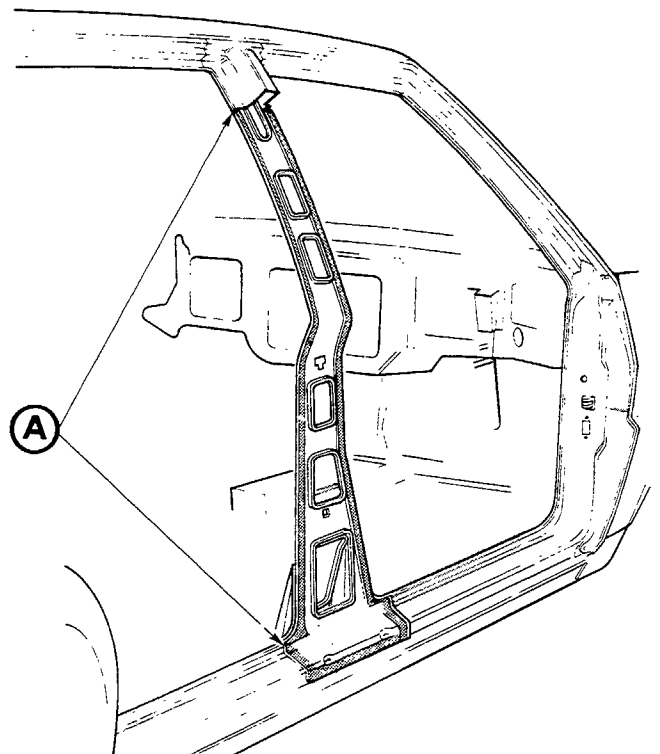

Measure distance A; apply a coat of protective zinc-based paint to the (shaded) areas which are to be welded.

**70.**

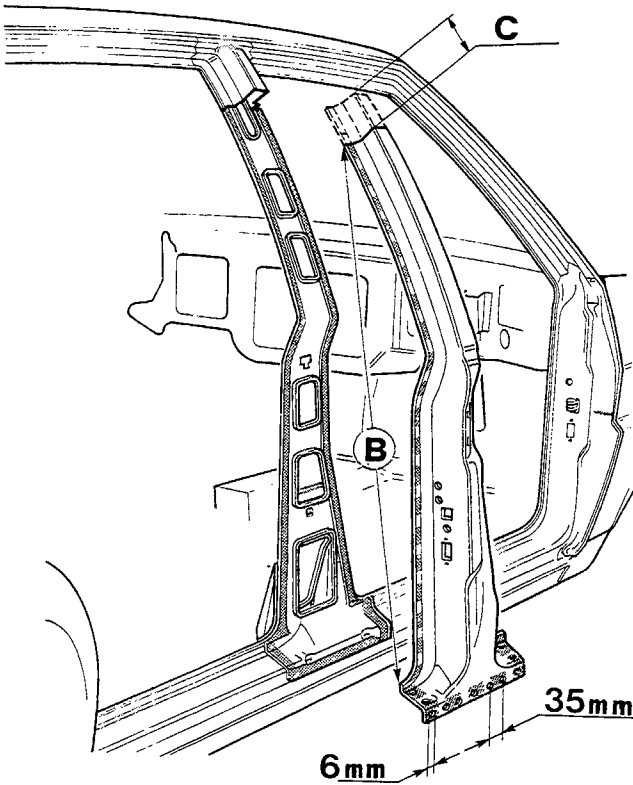

Mark off distance  $B = (A + 20\text{mm})$  on the replacement part and remove part C which is not going to be replaced.

Drill a series of holes as shown and grind and protect the welding areas with a zinc-based anti-rust agent.

Fit the replacement part in position, laying it over the non-replaced part; fix it with self-locking pliers and cut the overlapping ends together. Then remove the scraps.

Check the width of the door spaces.  
Weld joint A and joint B by the inert gas electrode method.  
Spot weld the outer section to the inner pillar.  
Braze along sections C - D.

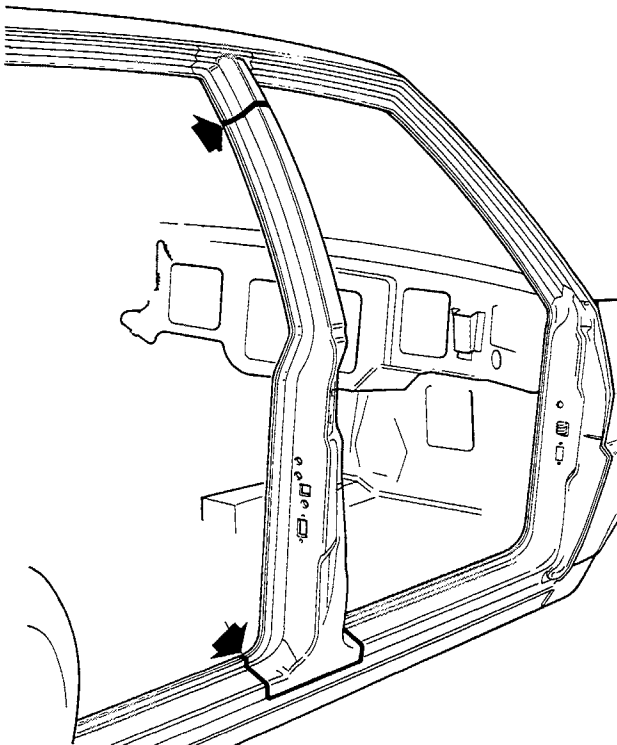
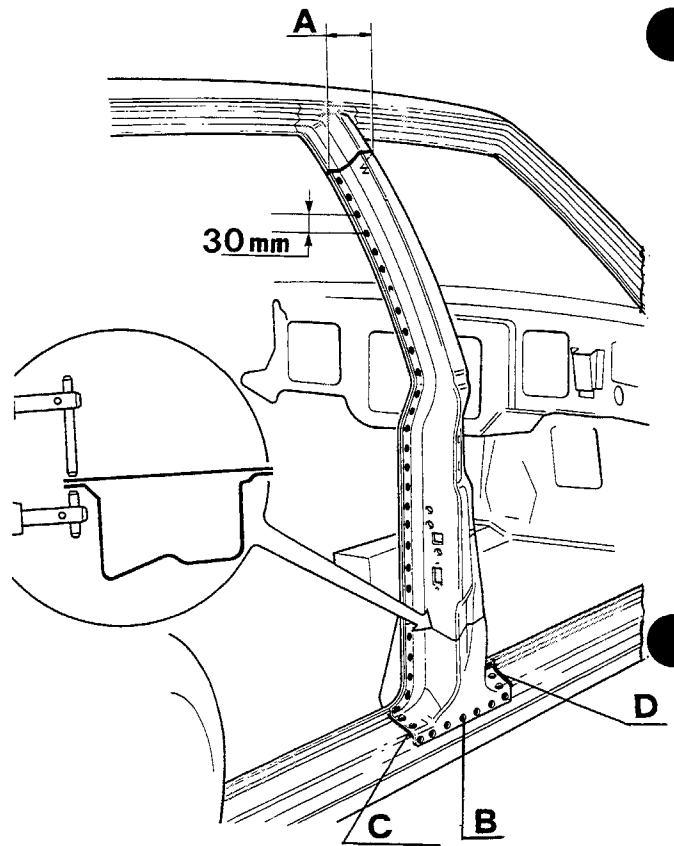

Finish all the welds carried out using the inert gas electrode method by grinding.

If necessary, make the joints on the pillar watertight and finish by filing.

Complete the operation by renewing the hot-setting sealant in the areas shown by the arrows.

## REPLACING REAR WING

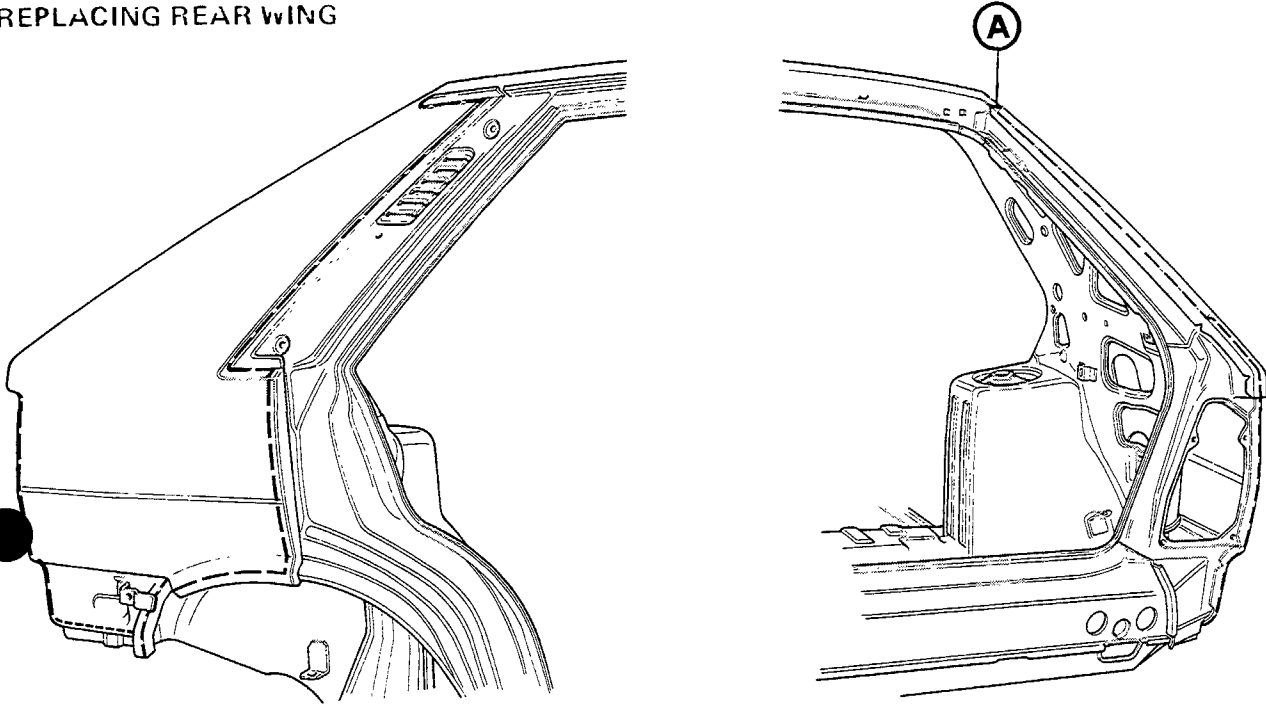

Cut the rear wing, along the broken lines, using a pneumatic chisel. Unweld the section marked A using an oxyacetylene torch.

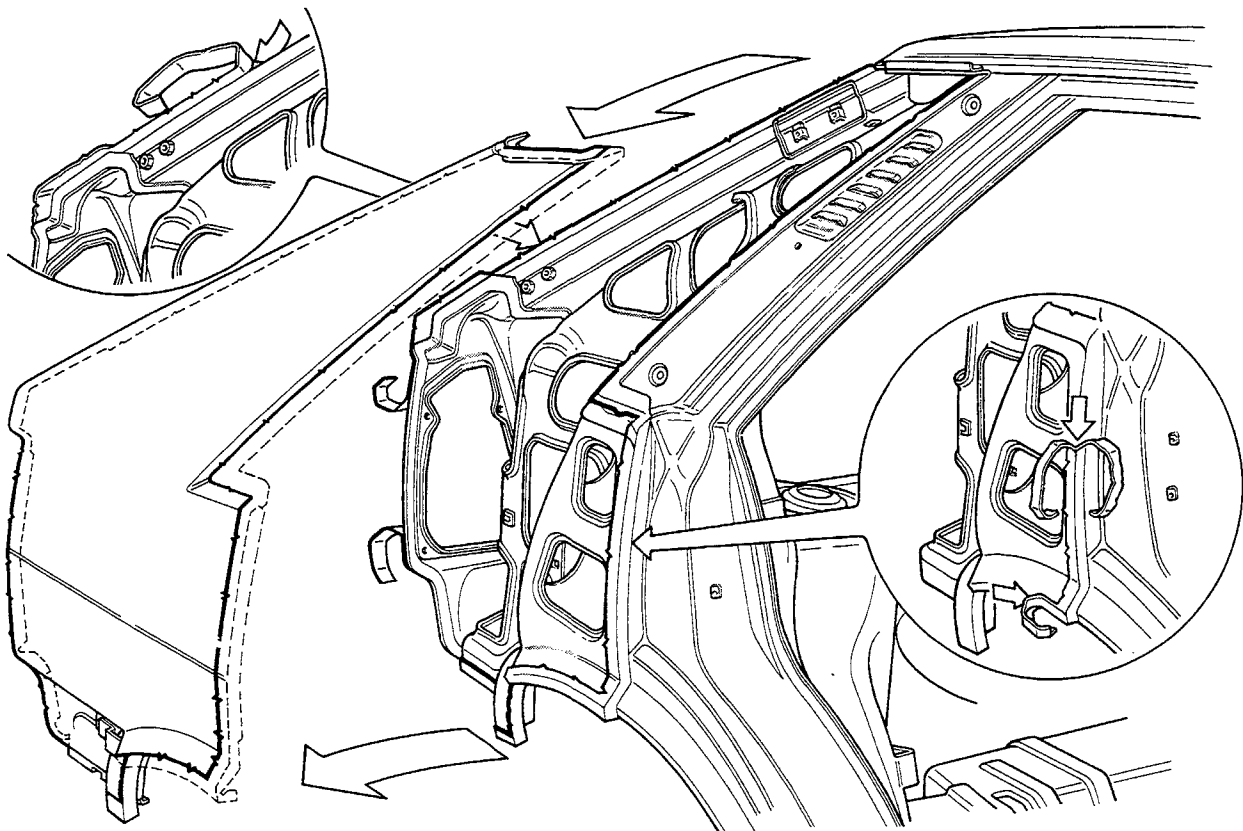

Detach the joining points from the scraps of sheet metal: remove the scraps of sheet metal and get rid of every trace of paint. Straighten the welding edges, remove the welding points using a grinder and protect by applying a zinc-based anti-rust agent.

**70.**

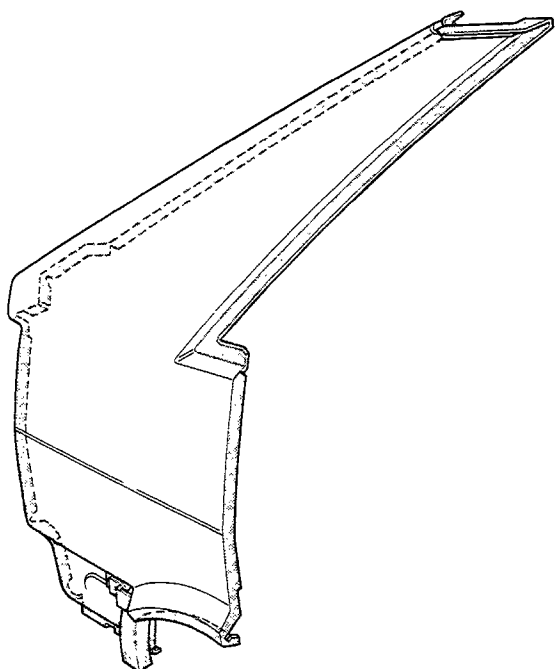

Grind the welding edges of the replacement part and protect by applying a zinc-based anti-rust agent along all the ground edges.

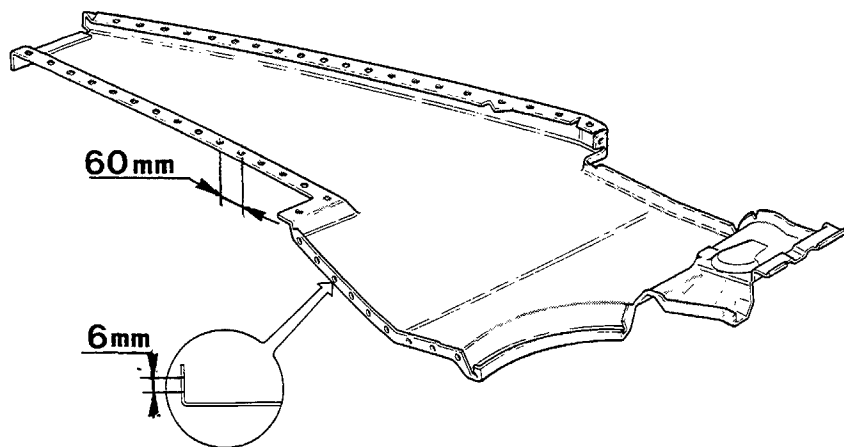

Drill a series of holes along the edges of the replacement part as shown in the illustration.

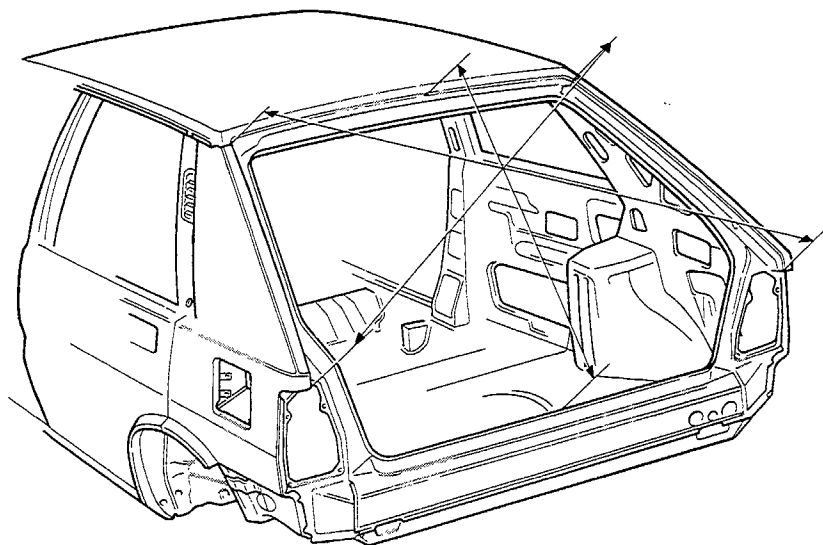

Fit the replacement part provisionally and check the diagonals. Fit the door and the hatchback and check that the ribs line up, that the clearances are uniform and that the surfaces of the wing lie in the same plane as adjacent parts.

Weld the wing to the door surround through the previously drilled holes in sections (1) and (2) by the inert gas electrode method. Spot weld the surround to the wheel arch and to the roof channel.

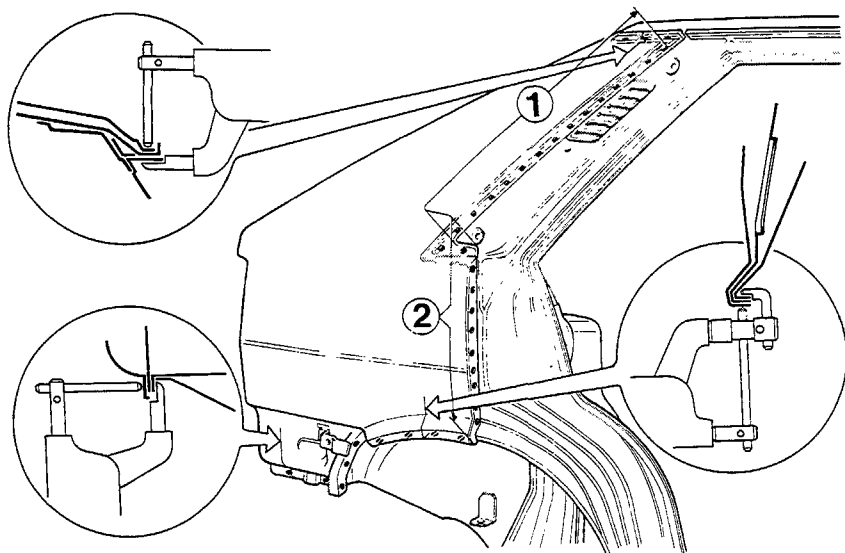

Braze the replacement part to the roof along section (1). Weld the wing to the hatchback compartment framework through the holes previously drilled in section (2) by the inert gas electrode method. Complete the welding of the replacement part using an electric spot welding gun.

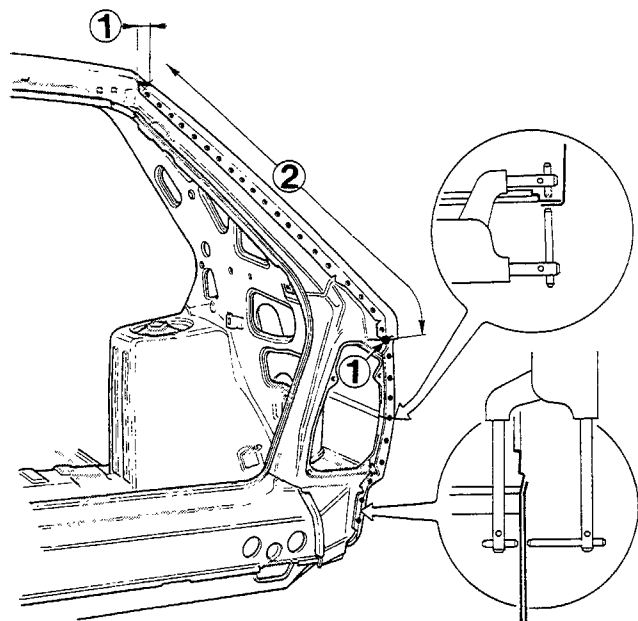

Apply hot-setting sealant for exterior use at the points shown.

Renew the anti-rust protection and soundproofing in the replaced box section.

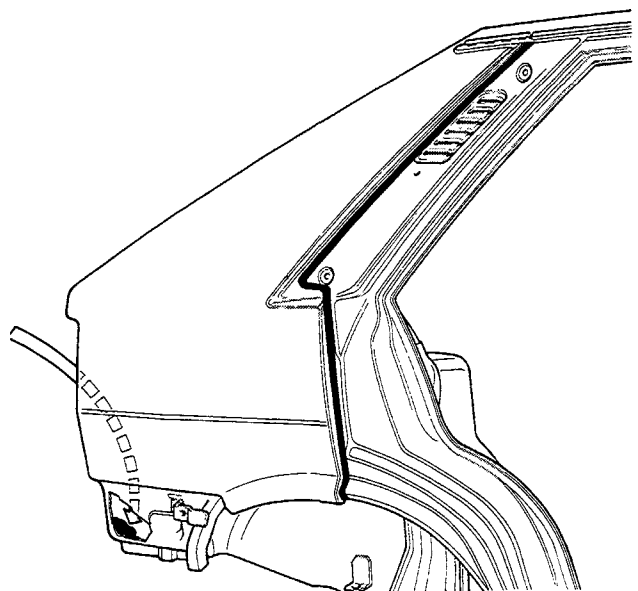

**70.**

**REPLACING REAR LIGHT CLUSTER SURROUND**

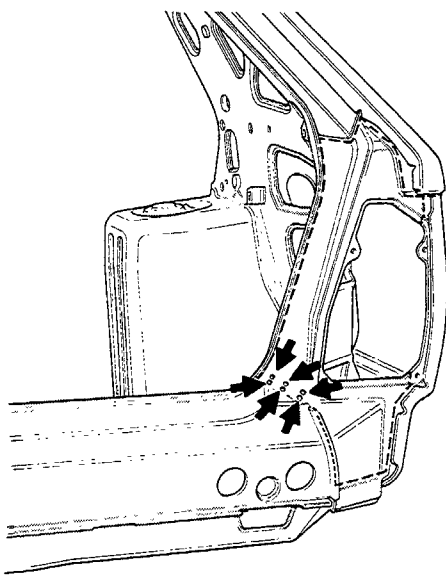

Cut the surround at the points shown using a pneumatic chisel and detach the welding points shown by the arrows, using a suitable milling cutter.

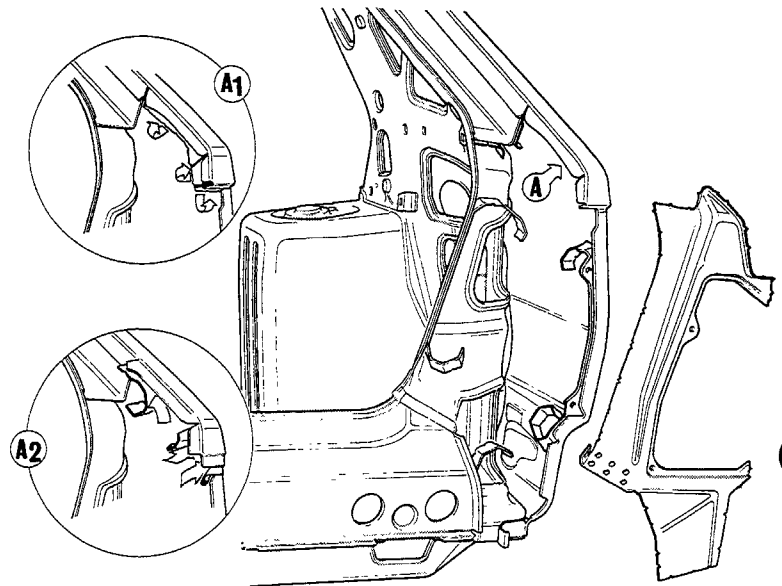

Remove the remaining scraps of sheet metal using tongs. Details A<sub>1</sub> - A<sub>2</sub> show in close-up the sequence of operations to be carried out in fin section A.

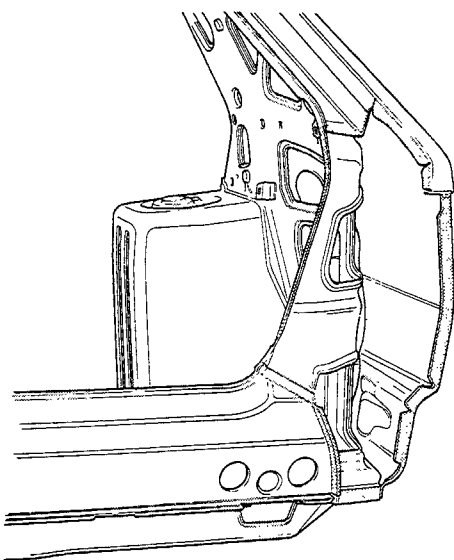

Straighten the fins shown using a hammer and shaped block and finish them using a grinder.

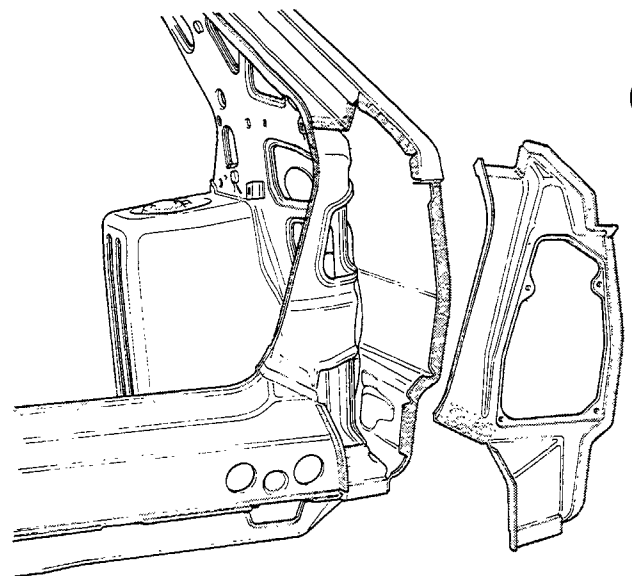

Grind the welding edges of the replacement part and protect the areas shown by applying a zinc-based anti-rust agent.

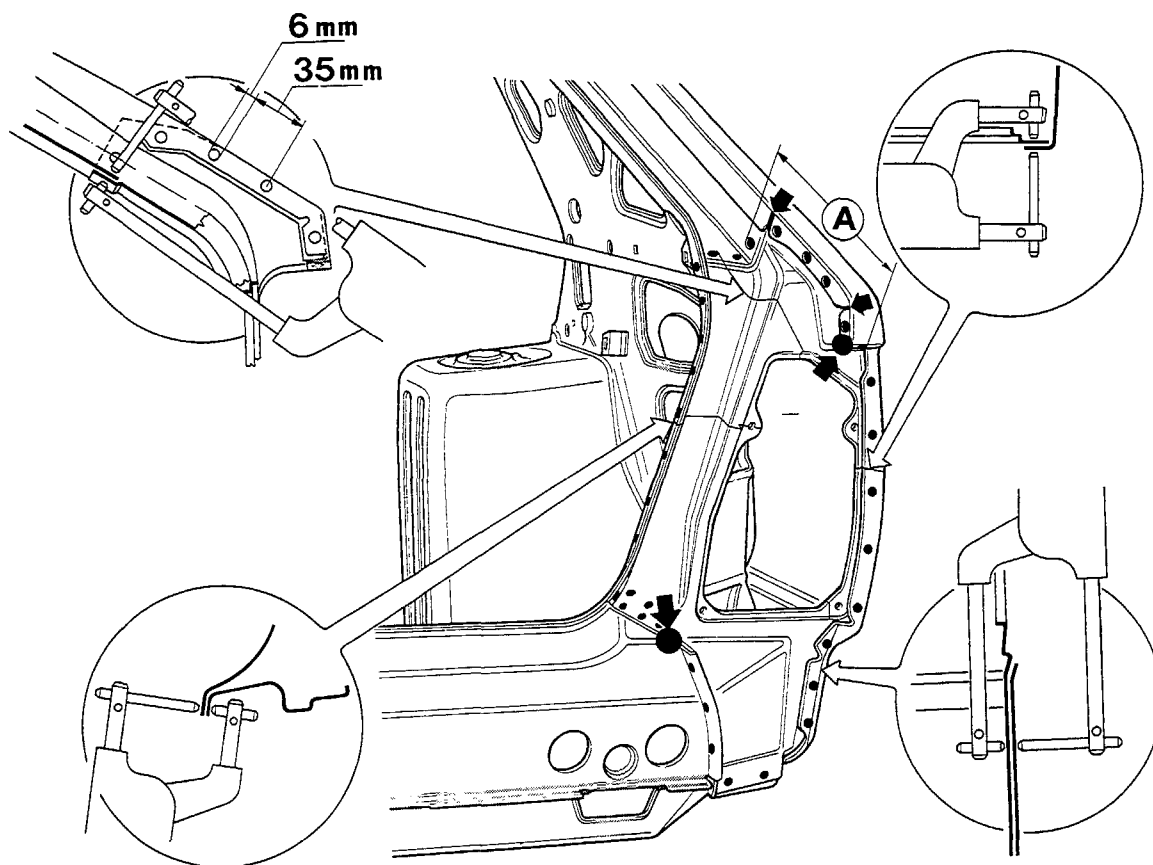

Fit the replacement part in position and fix it using self-locking pliers. Drill a series of blind holes in section A of the wing, the dimensions of which are shown in the close-up view, and then weld the wing to the replacement part by the inert gas electrode method. Spot weld the other parts of the replacement part to the bodyshell. Complete the operation by brazing the points shown by the black arrows.

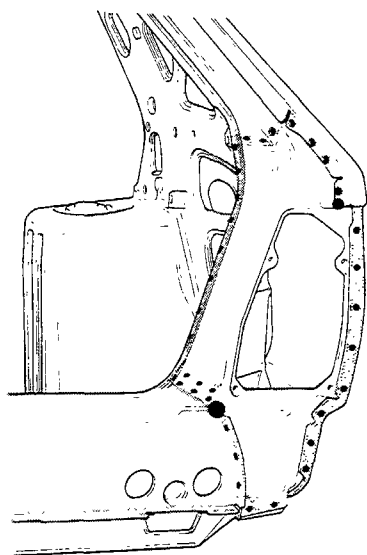

Finish the brazing at the points shown using a grinder.

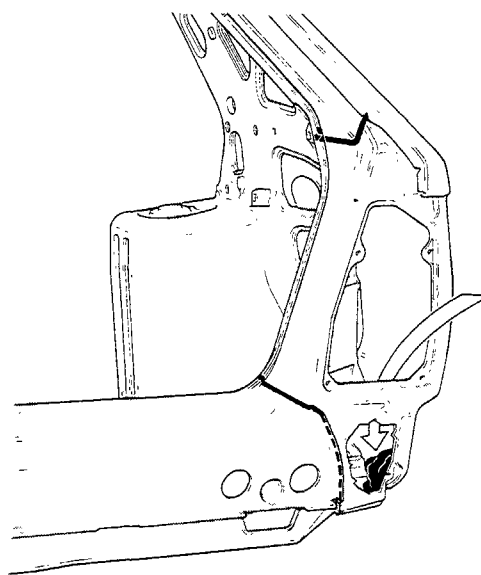

Renew the sealant for exterior use in the areas shown. Apply anti-rust protection and soundproofing in the replaced box section.



## BONNET LID

## Vertical adjustment

The arrows show the direction in which the bonnet lid can be adjusted by means of the slots on the hinges.

**NOTE** *It is necessary to remove the radiator trim in order to be able to get at the bolts for making vertical adjustment to the bonnet lid.*

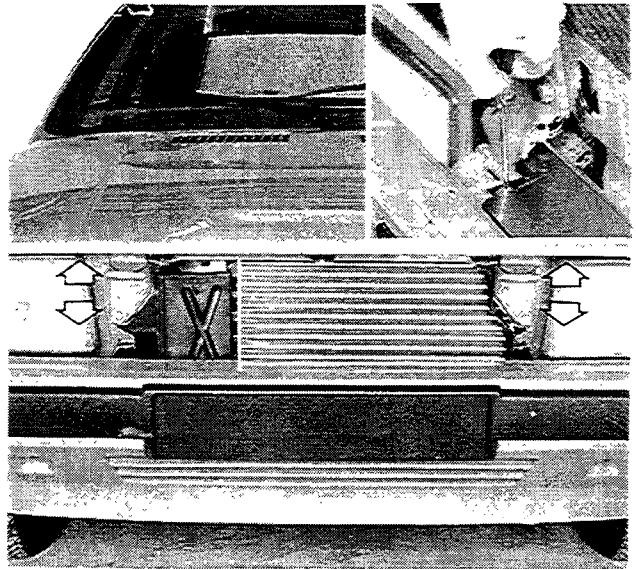

## Adjusting transverse position

The arrows show the direction in which the bonnet lid can be adjusted by means of the slots on the hinges.

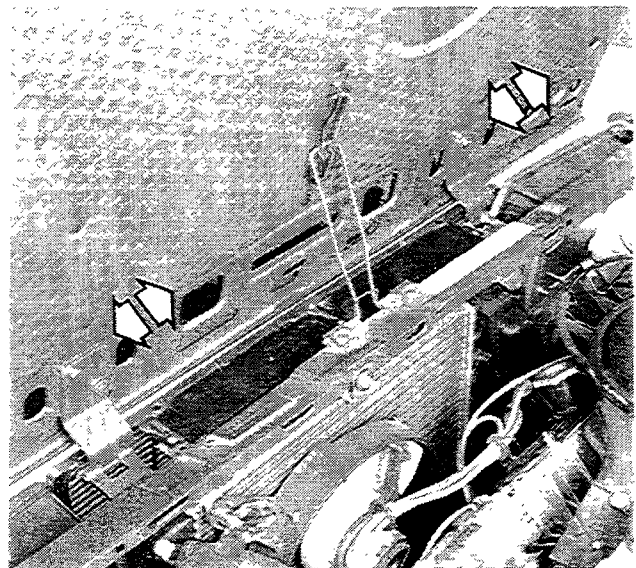

## Adjusting the device for locking the bonnet lid

Getting the bonnet lid to lock properly is done by adjusting not only the bolts securing the 2 locking devices, but also the rubber blocks at the ends of both the engine compartment and the bonnet lid.

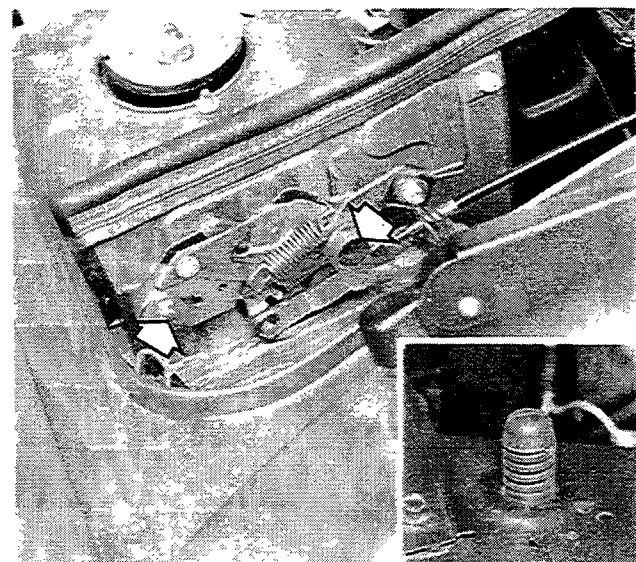

Straighten the welding edges on the body shell using a hammer and shaped block. Grind all edges on which the welds shown by the shading are to be carried out. Protect all the shaded areas on which the welds are to be carried out by coating with zinc. The black arrows show the holes previously drilled for removing the welding points: check that these holes go right the way through and if they do not, re-drill them using a 6mm drill bit.

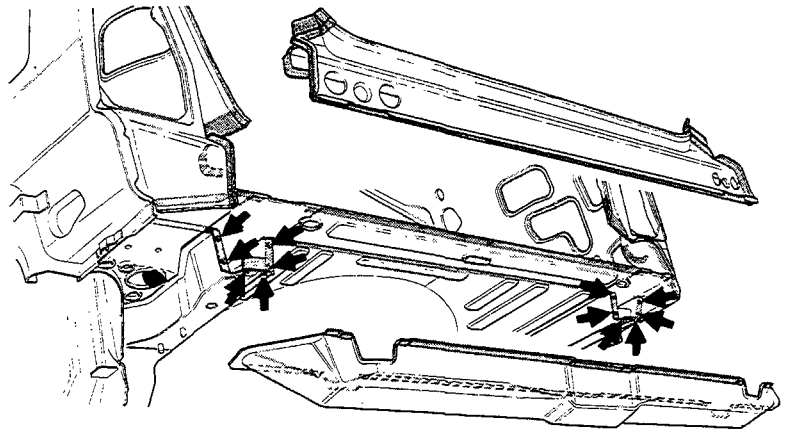

Drill the floor in the area shown by the arrows using a 6mm diameter drill bit in order to enable the fins of the underlying crossmember to be welded to the floor. Fit the 2 replacement parts in position fixing them by means of self-locking pliers and check the depth of the rear door space and that the diagonals of this space are equal. Spot weld the lower crossmember to the floor as shown in close-up A<sub>1</sub>.

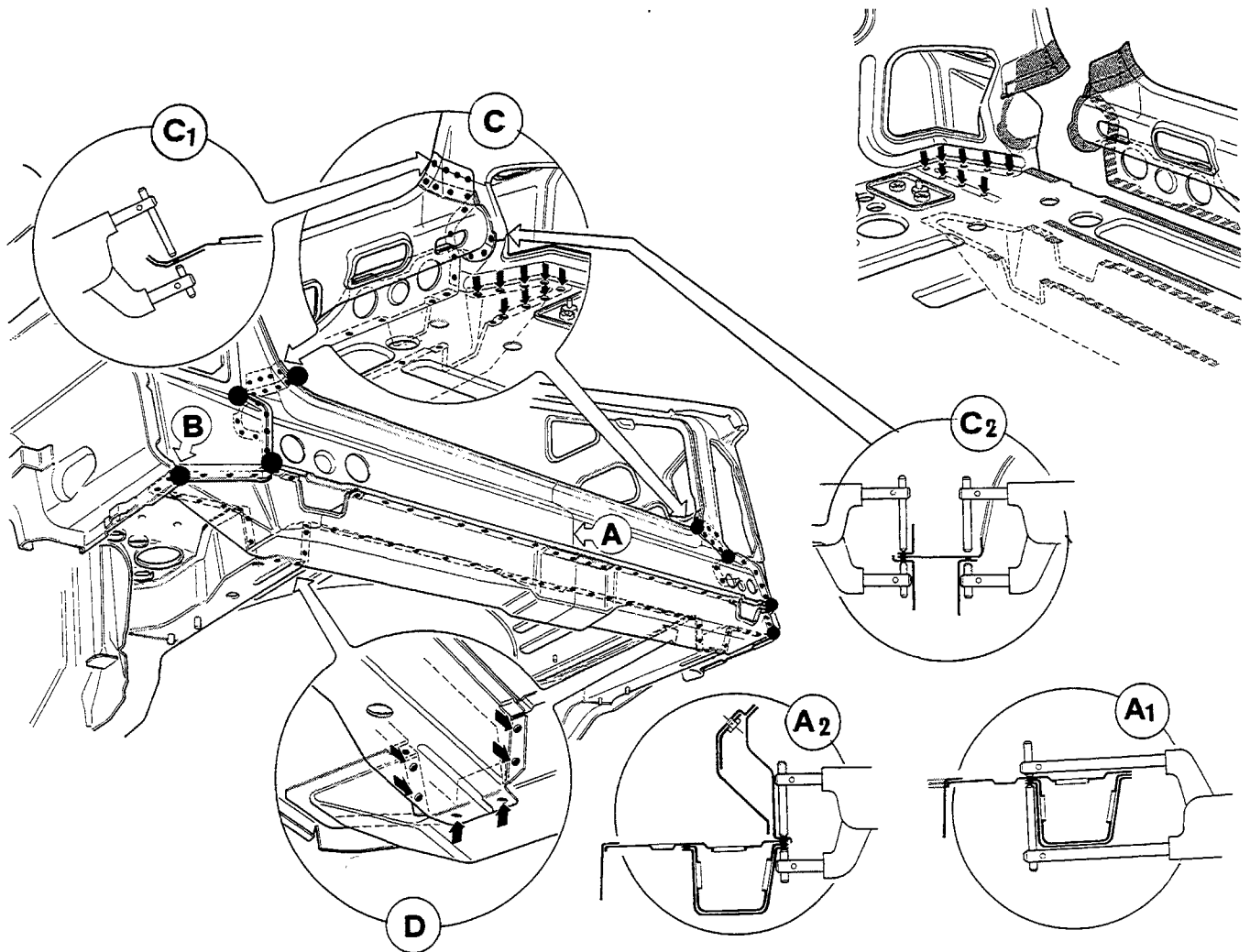

Continue welding the fins to the crossmember filling the holes shown in close-up C by the arrows using an inert gas welder. Weld the crosspiece to the longitudinal members filling the holes shown in close-up D using an inert gas welder. Spot weld the rear section to the crossmember and laterally to the light cluster surround, as shown in close-ups A<sub>2</sub>, C<sub>1</sub> and C<sub>2</sub>.  
Brazed the joints at the points shown by the letter B.

**70.**

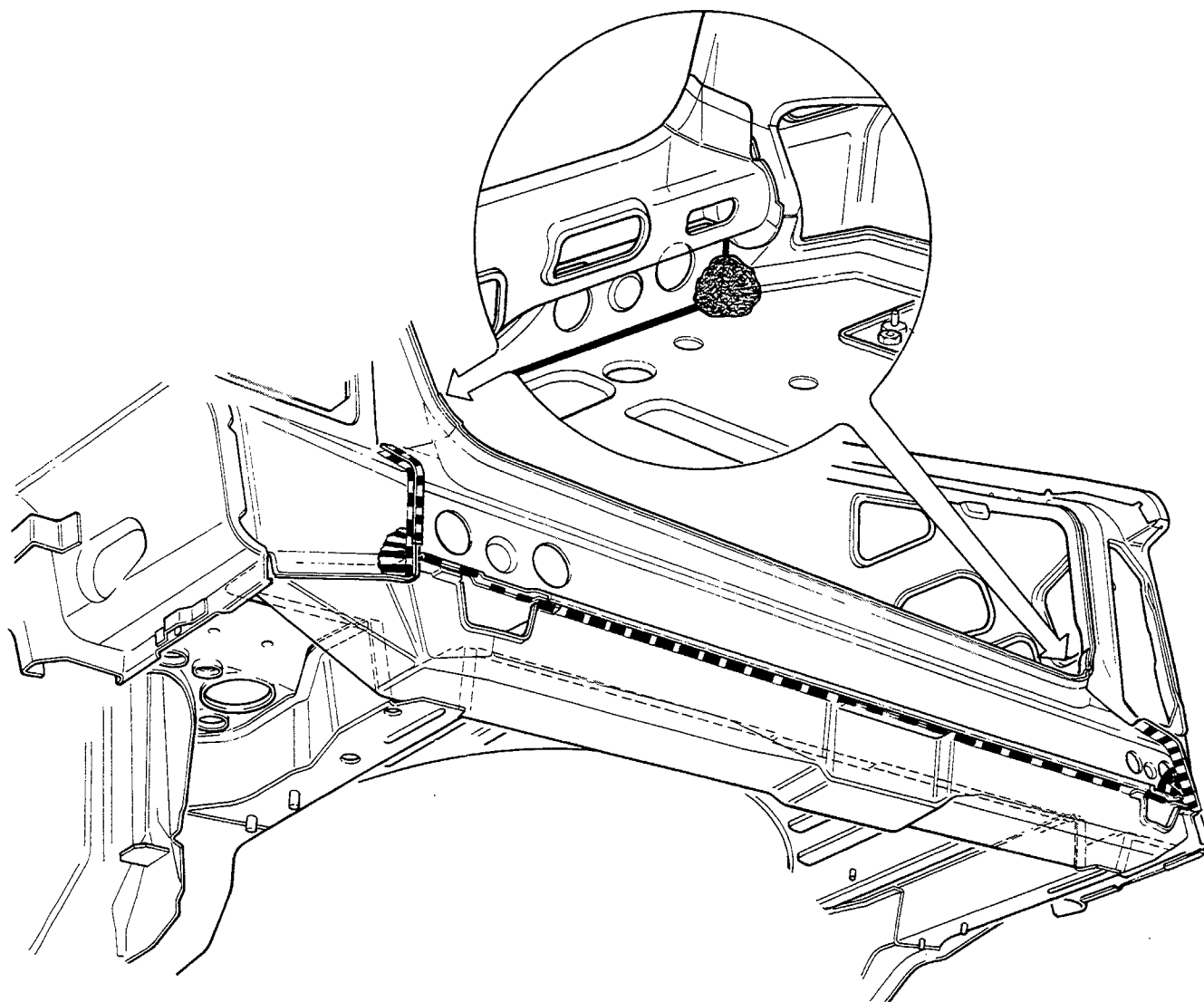

Finish the brazing work using a grinder. Renew the sealing in the areas shown with a heat-setting plastic sealant for interior use. Apply anti-rust protection and soundproofing in the replaced box sections.

BODYWORK COMPONENTS SUPPLIED AS SPARES

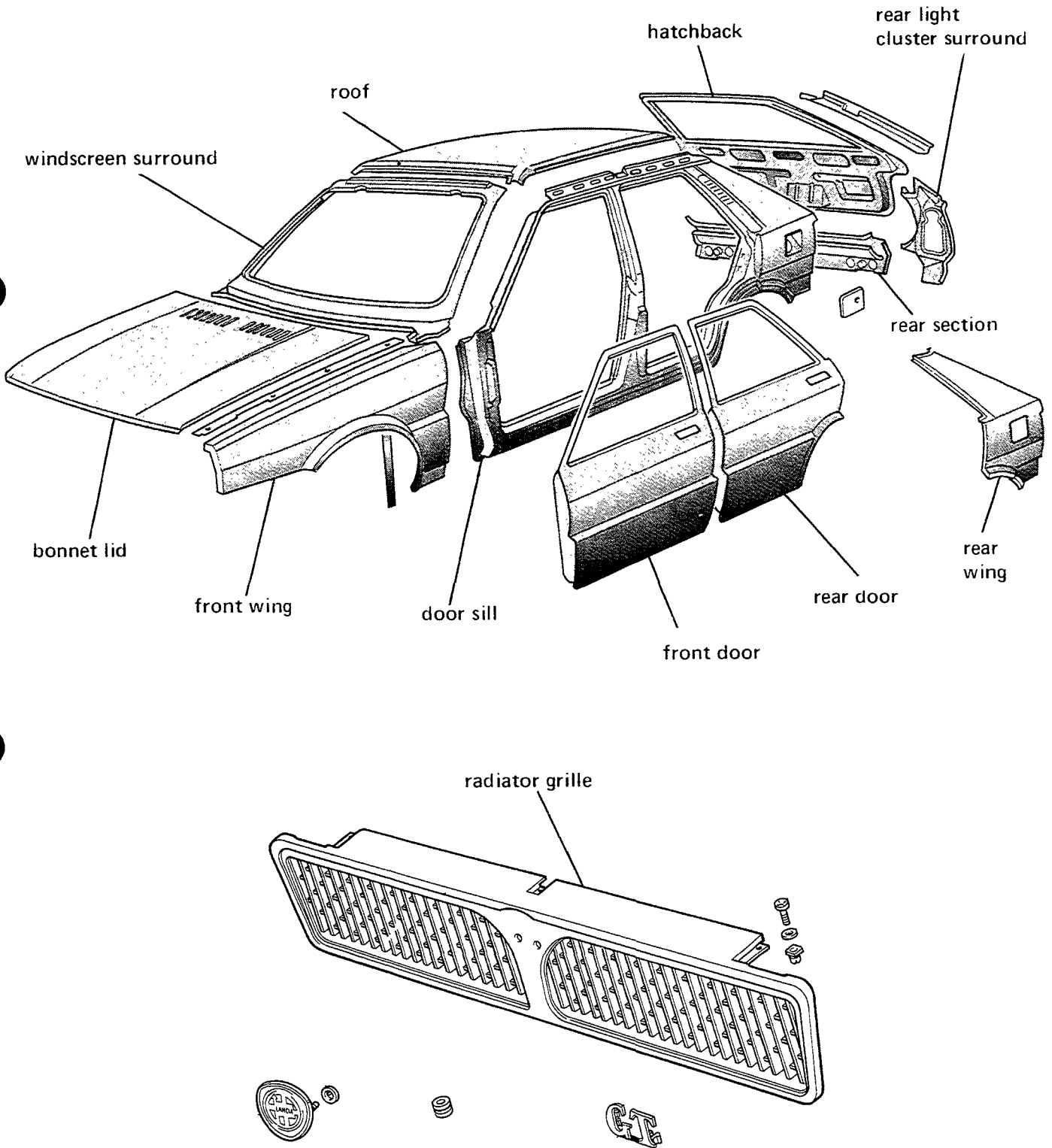

**70.**

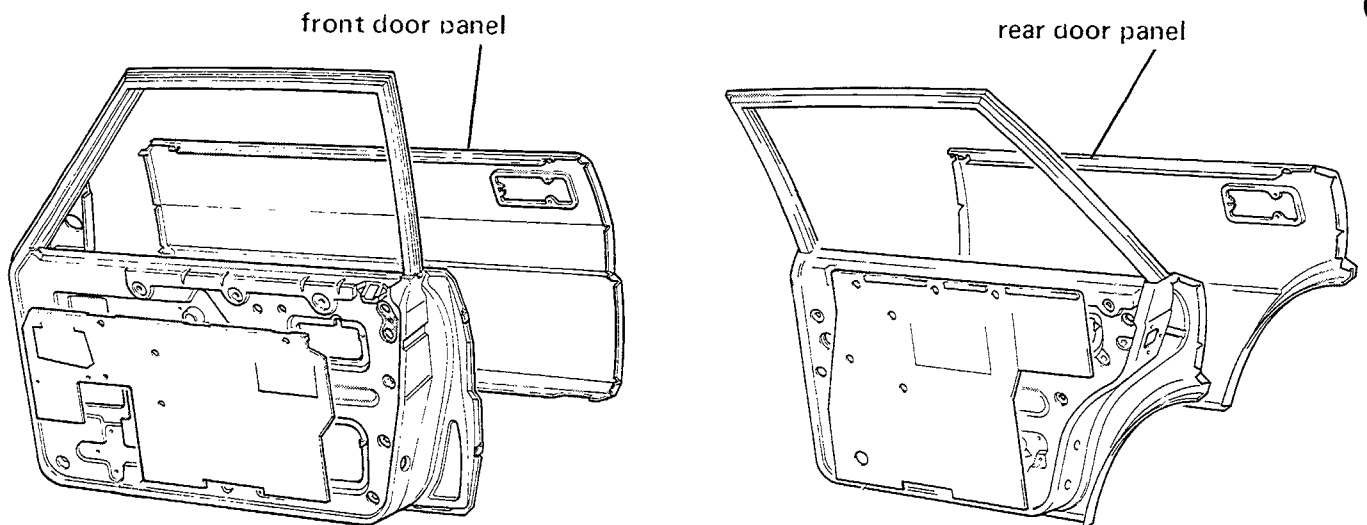
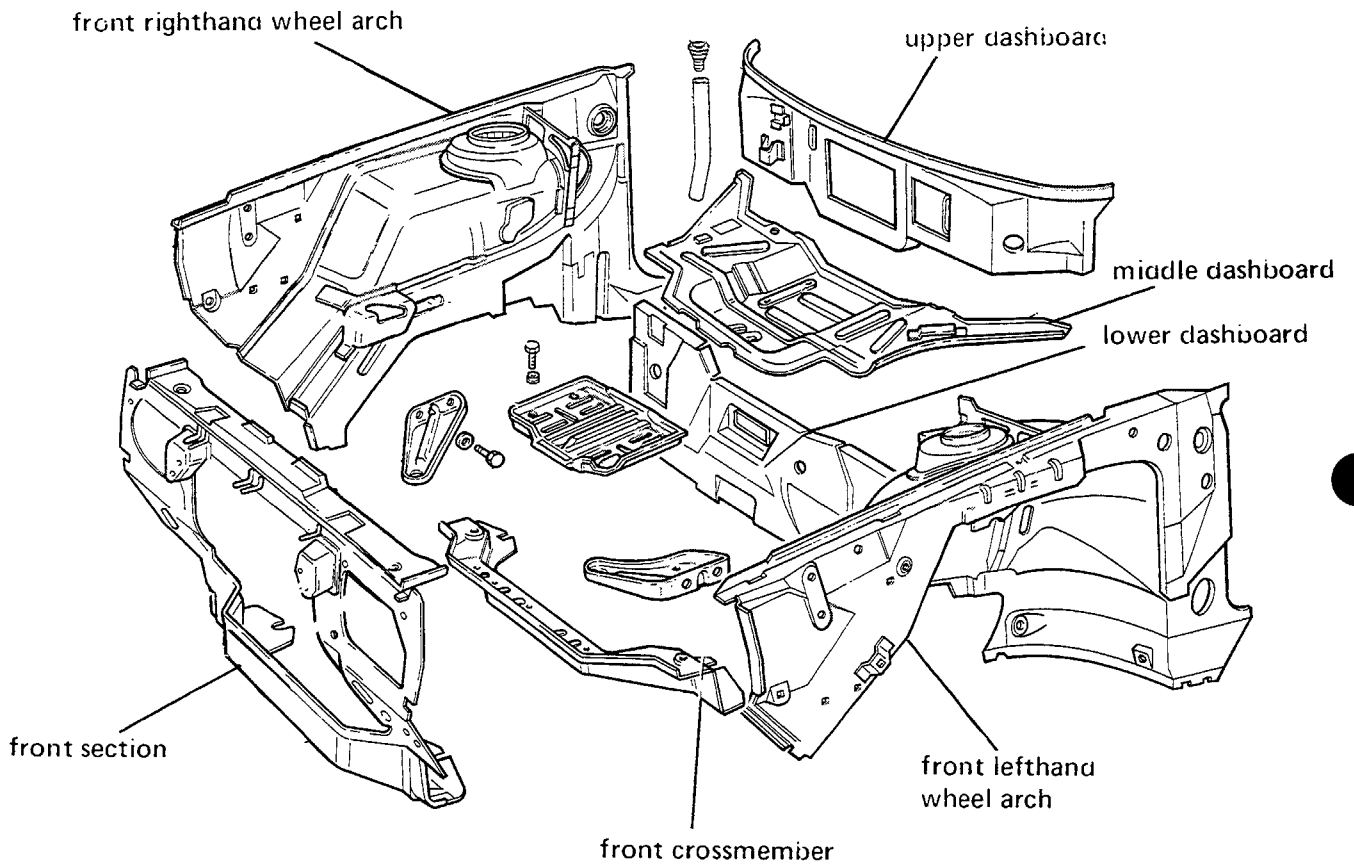

forward central crossmember

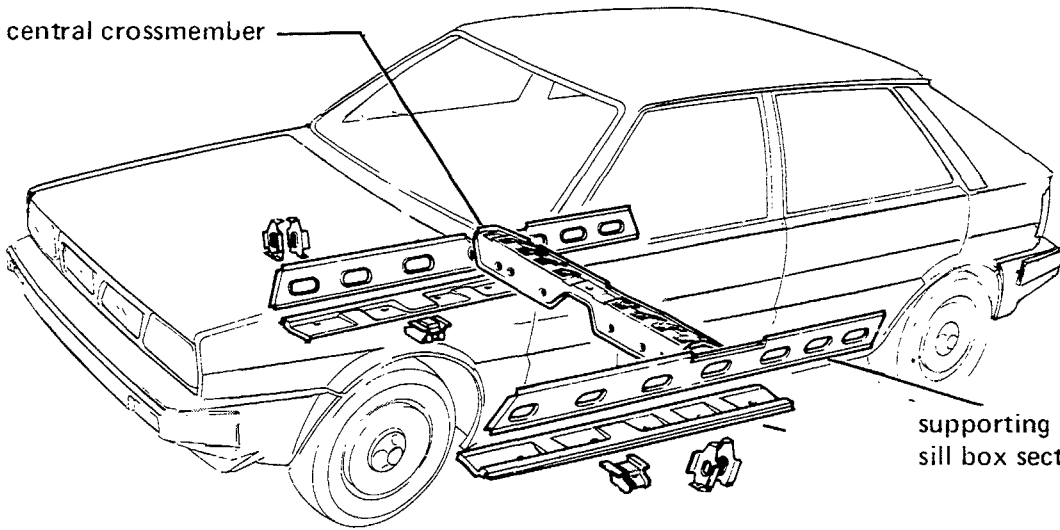

supporting member for door sill box section

lower rear crossmember

upper rear crossmember

rear central crossmember

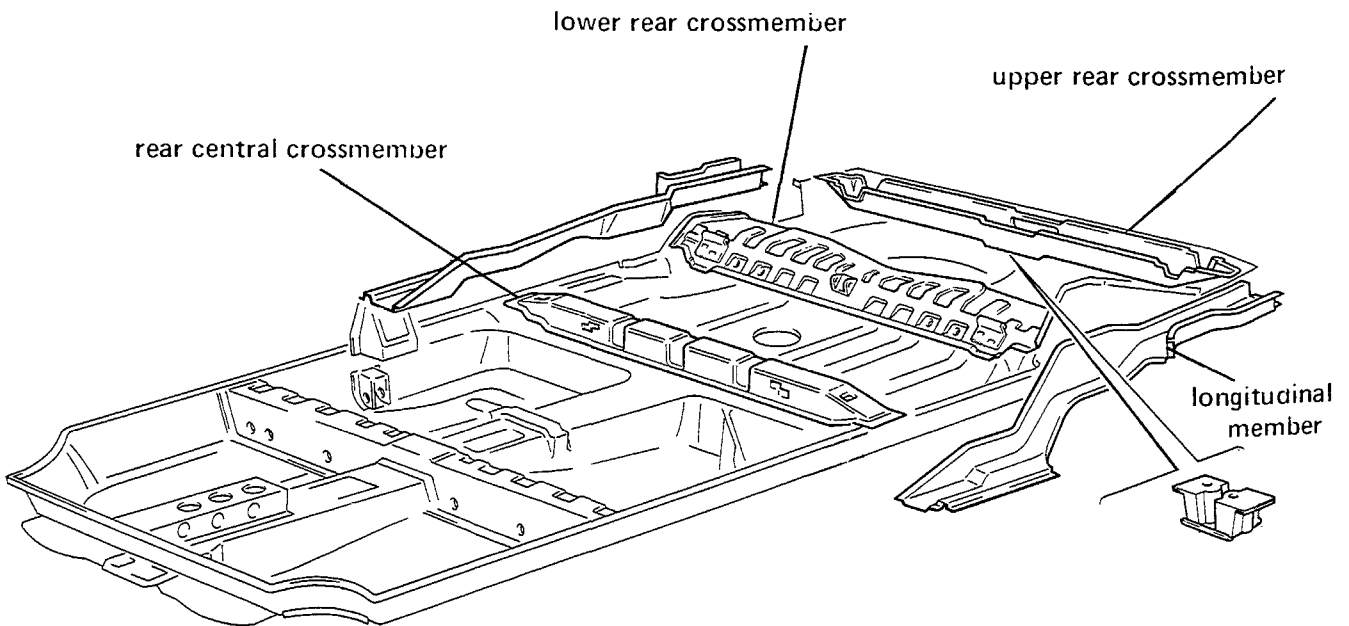

longitudinal member

**70.**

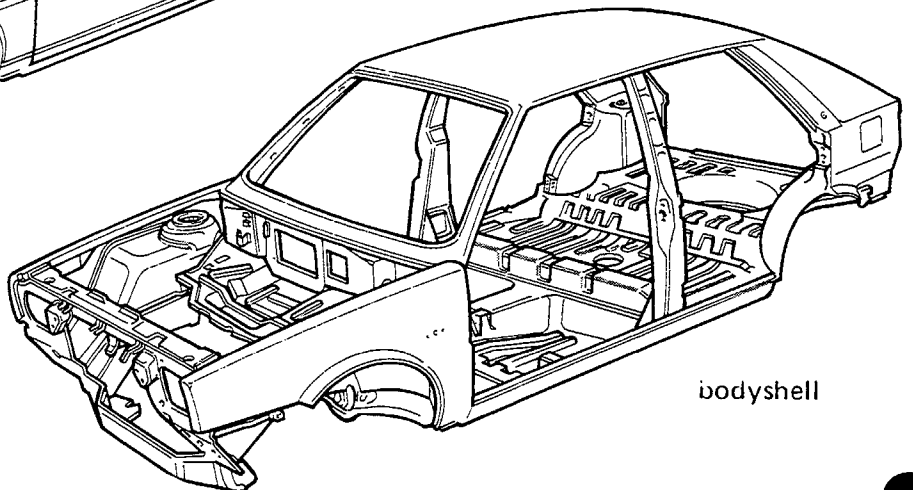
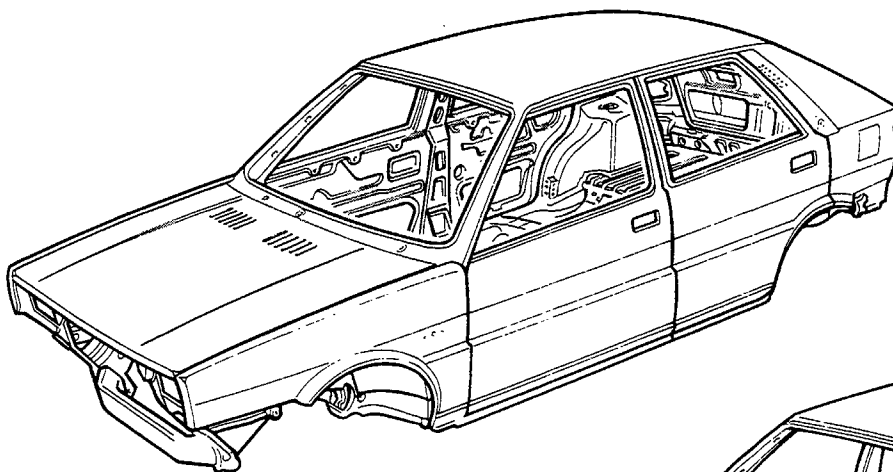
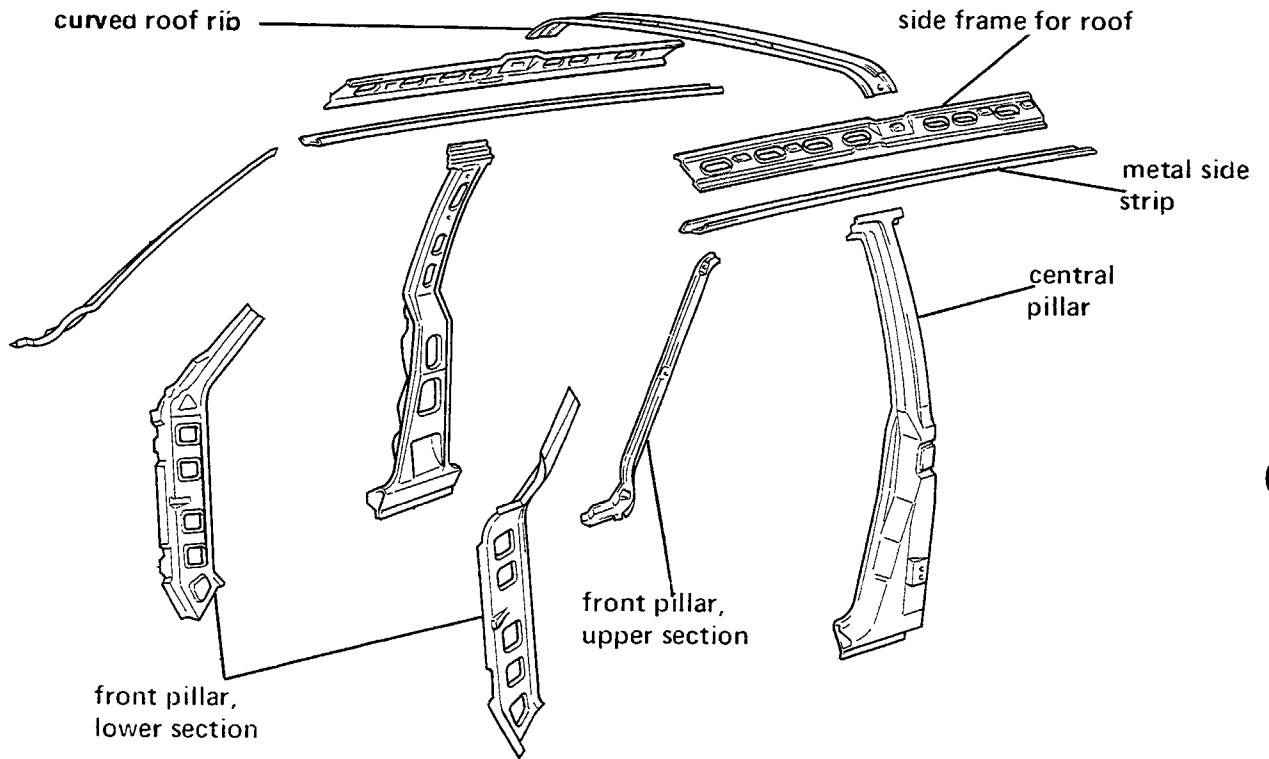
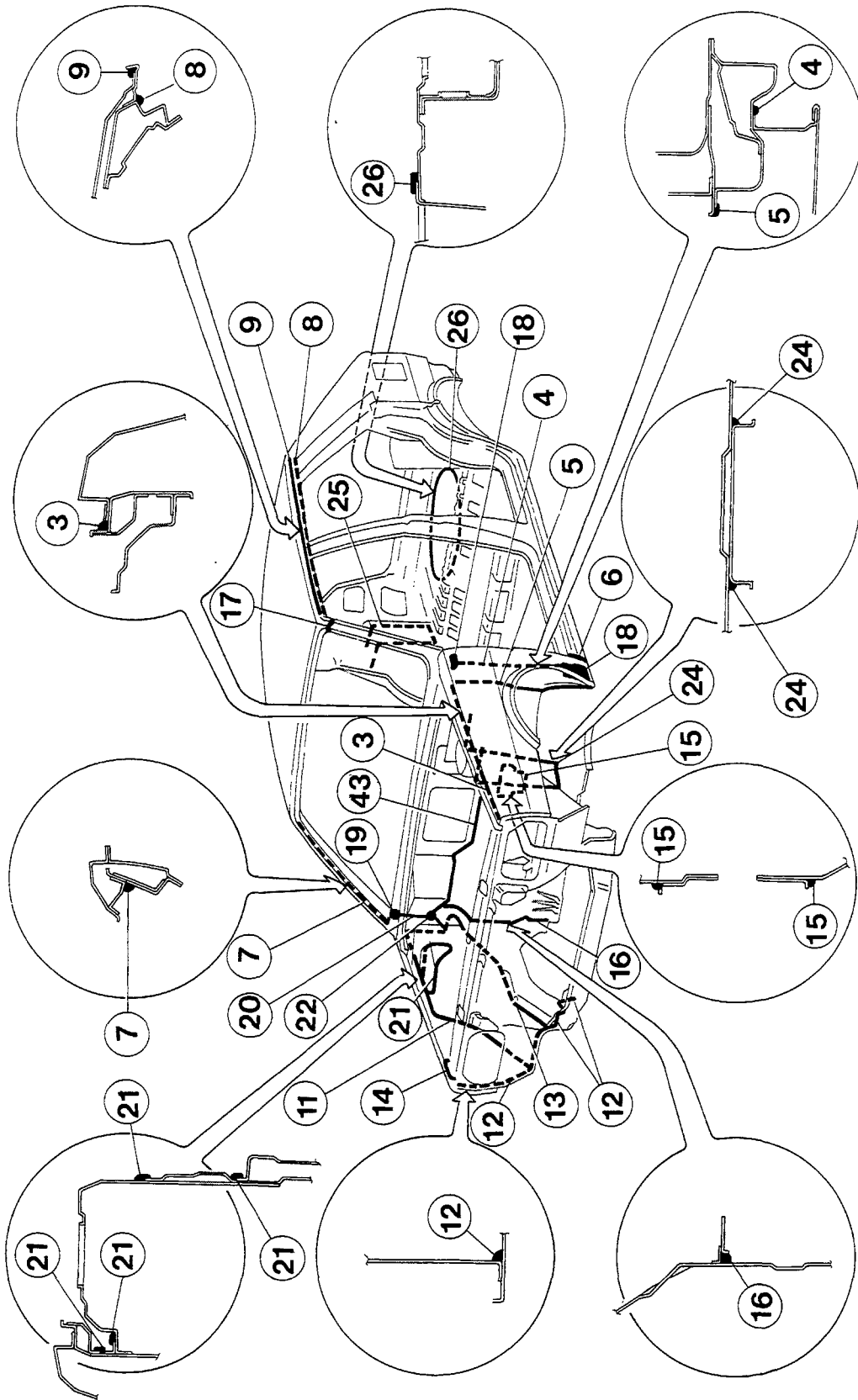
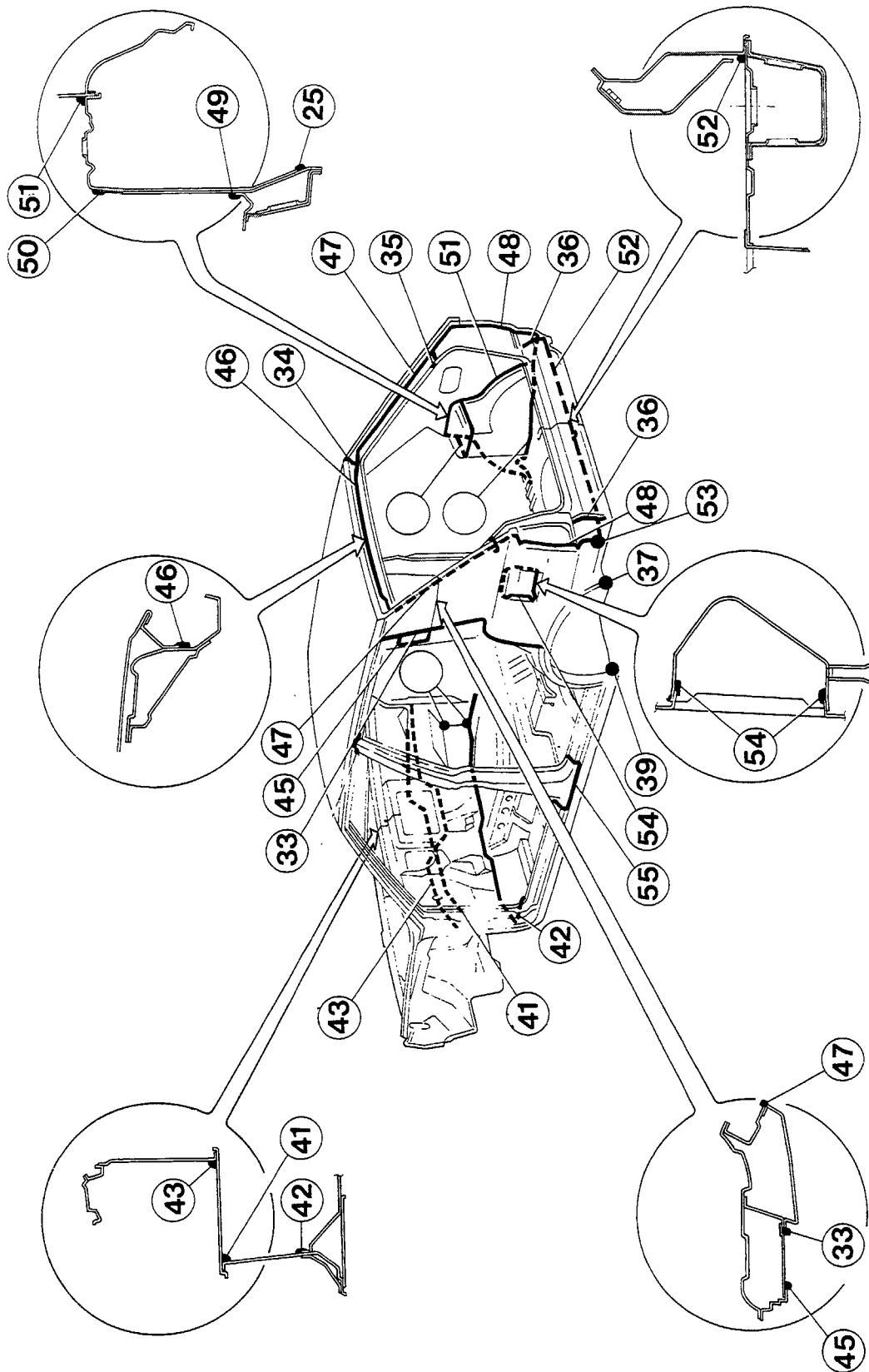

DIAGRAM SHOWING WHERE TO APPLY SEALANTS PRIOR TO PAINTING





**70.**



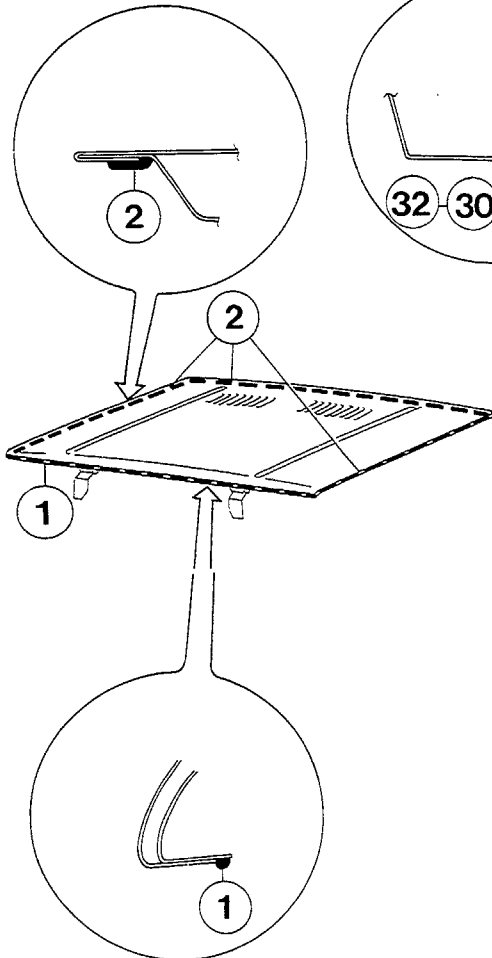
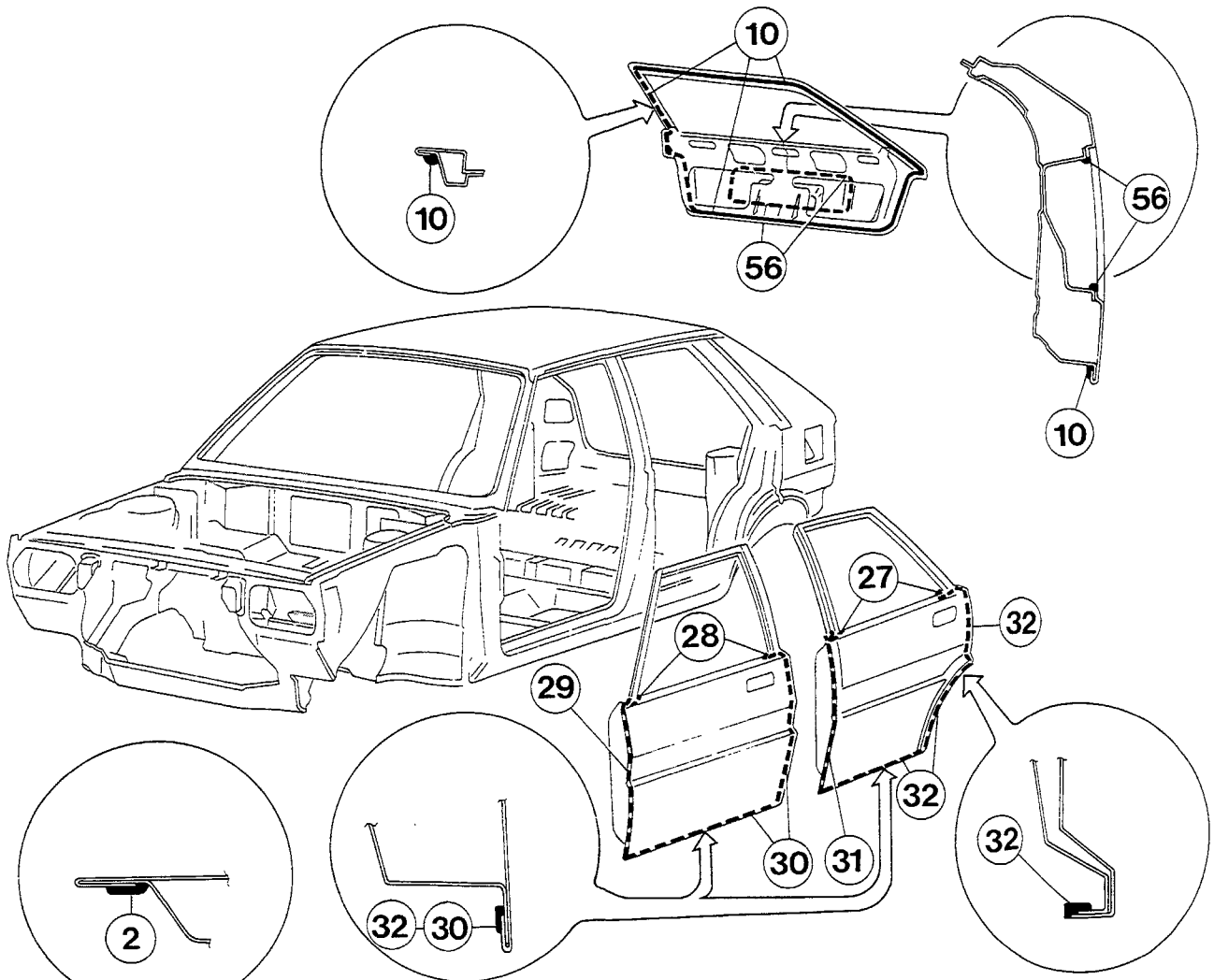

TYPES OF SEALANT

Reference no.	Name
1 - 2 - 3 - 6 - 7 - 8 - 9 10 - 17 - 27 - 28 - 29 - 30 - 31 - 32 33 - 34 - 35 - 36 - 45 - 46 - 47 - 48 54 - 55 - 56	Hot-setting sealant for external use, type IVI no. 854765
4 - 5 - 11 - 12 - 13 - 14 - 15 - 16 - 20 21 - 24 - 25 - 26 - 41 - 42 - 43 49 - 50 - 51 - 52	Hot-setting sealant for interior use type IVI no. 854762 or IVEST R 1200
18 - 19 - 22 - 23 - 37 39 - 53	Hot-setting mastic, type IVI no. 857477

**70.**

BODYWORK COMPONENTS PROTECTED WITH WAXY-OIL

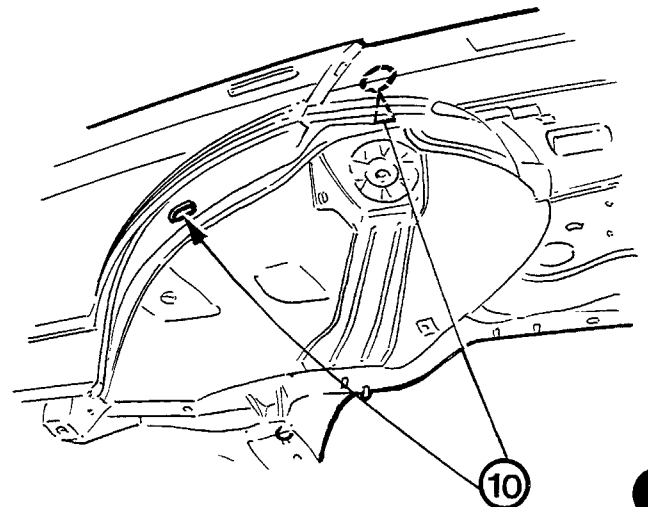
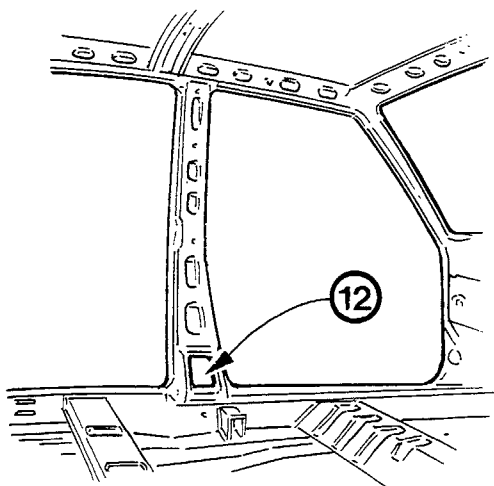
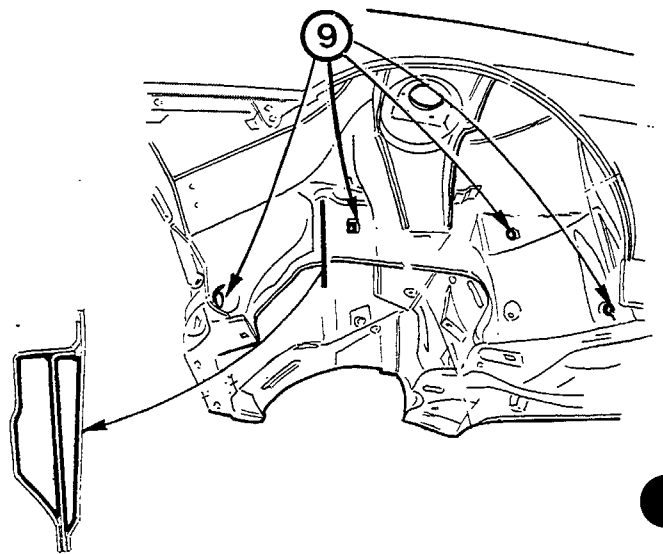
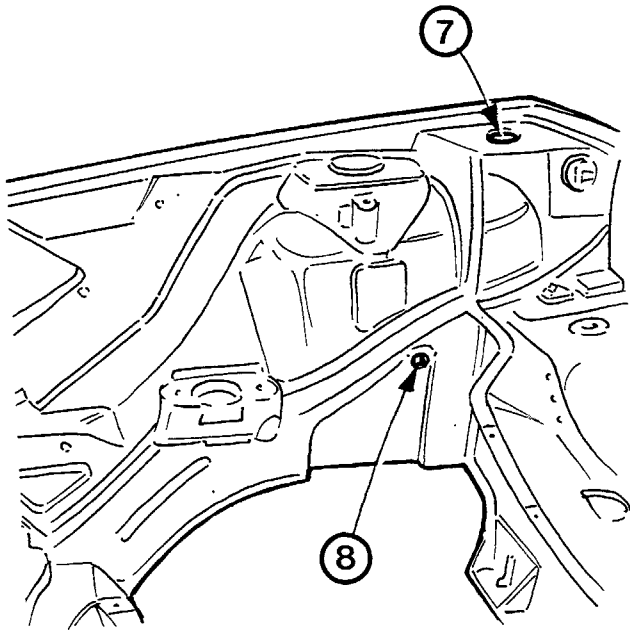
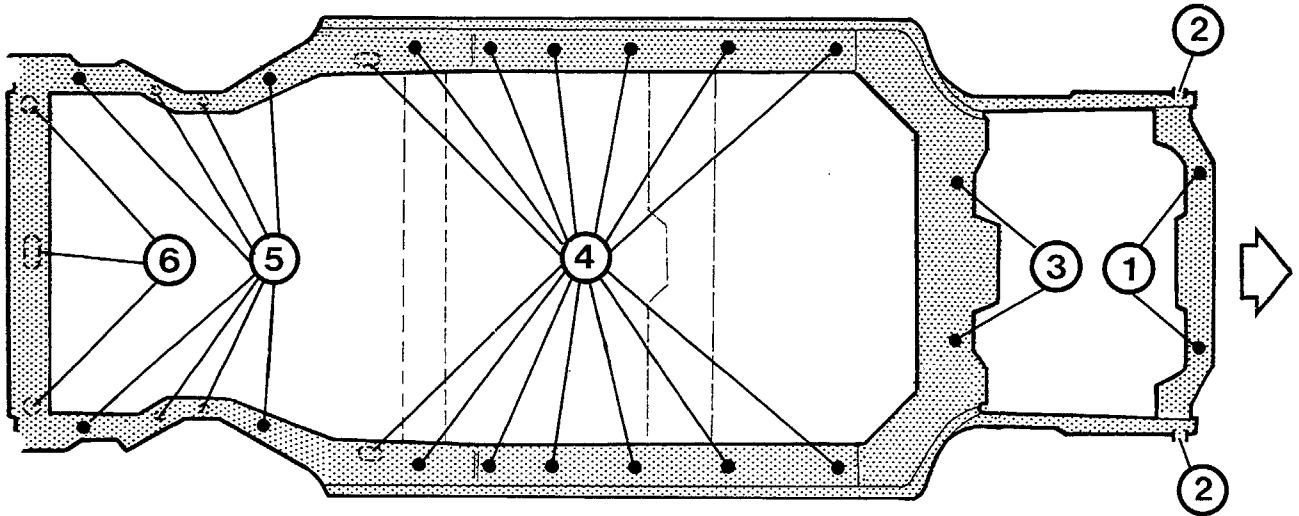

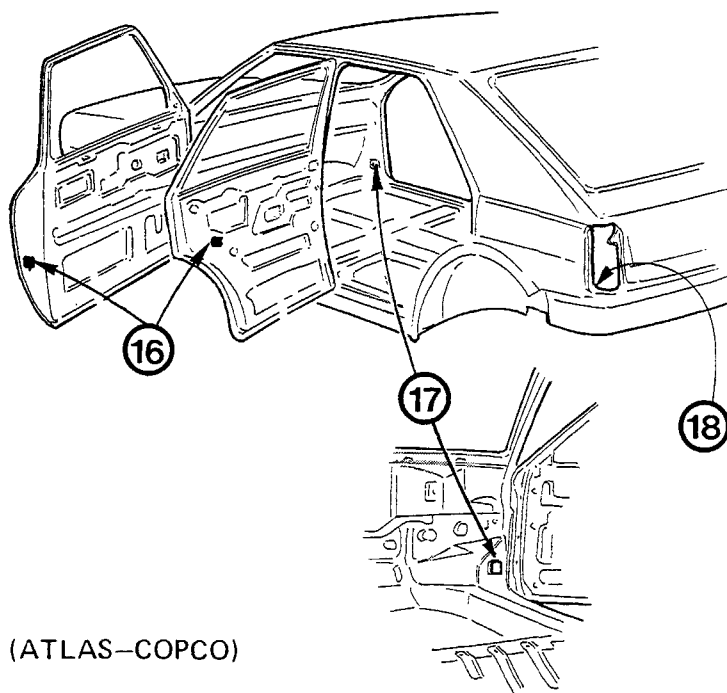
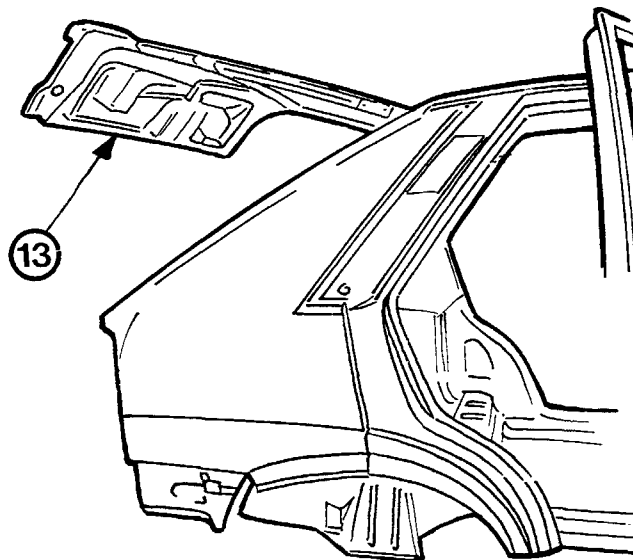
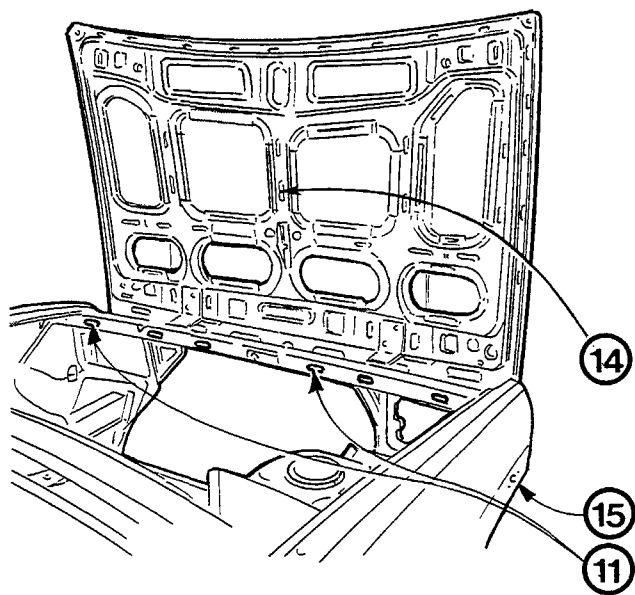

AREAS PROTECTED WITH (ATLAS-COPCO) HIGH PRESSURE SYSTEM

1. Front section lower crossmember
2. Front side longitudinal members
3. Boxed front suspension supporting cross-member
4. Door sill box section, external part
5. Rear floor side longitudinal members
6. Lower rear boot crossmember
7. Front wheel arch upper box sections
8. Front wheel arch lower box sections
9. Front wheel arches, shock absorber fixing turret area
10. Rear wheel arches, shock absorber fixing turret area
11. Front section upper crossmember

AREAS PROTECTED WITH (PROBE) LOW PRESSURE SYSTEM

12. Central pillar lower support
13. Lower framework for boot lid
14. Lower and upper framework for bonnet lid
15. Front wings, internal headlamp housing area
16. Front and rear door framework
17. Front pillars
18. Rear wing near the wheel arch, from the inside of the car

**70.**

DIAGRAM SHOWING PANEL SECTIONS PROTECTED WITH ZINCROMETAL

